

	MODEL	DN	Kvs [m ³ /h]
2 way	2TBB15R1	1/2"	0.2
	2TBB15R2	1/2"	0.5
	2TBB15R3	1/2"	1
	2TBB15	1/2"	2,5
	2TBB20	3/4"	4
	2TBB25	1"	8
	2TBB32	1 1/4"	12
	2TBB40	1 1/2"	21
	2TBB50	2"	33
3 way	3TBB15	1/2"	2
	3TBB20	3/4"	5
	3TBB25	1"	10
	3TBB32	1 1/4"	16
	3TBB40	1 1/2"	25
	3TBB50	2"	38

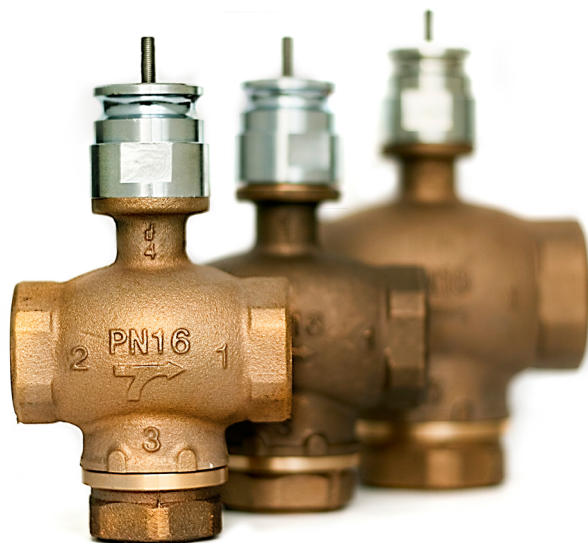

APPLICATION AND USE

These valves can be used either for fluid control or detection in domestic hot water, air-conditioning, thermoventilation and heating plants, both environmental and industrial, and in machines for product thermal process. Three-way valves should be used only as mixing valves; angle way should never be used for control purposes.

MANUFACTURING CHARACTERISTICS

Suitable fluids are: water, water/glycol mixture (25% max) and water/NaCl or CaCl₂ mixture (15% max).

The use of steam is allowed only with 2 way valves up to 3/4" and, in any case, steam should not reach saturation conditions.

Controlli can not accept any responsibility in case of use of not listed fluids.

Materials exempt from dezincification are used for brass components in contact with fluids.

Valves are used in closed circuits; if the circuit is open they can be subject to deposit. In this case we suggest a frequent maintenance or the use of filters.

OPERATION

2TBB are globe valves equal percentage characterised; the valve is closed when plug is lifted.

3TBB valves have a parabolic plug with modified characteristic; if the plug is back the direct way is open.

The angle way has a linear characteristic. It guarantees an excellent operation both as mixing as well as diverting valve. In this case you have to reduce the performances to 1/3 of the indicated value.

These valves are designed to be motorized by MVH and MVE actuators; to use MVB or MVE.S actuators please contact our Technical Dept.

APPLICATION FOR MIXING VALVE

These valves must always be installed with two inlet streams and one outlet stream (as mixers). Reversal of direction will cause vibration and water hammer which will damage both valve and actuator.

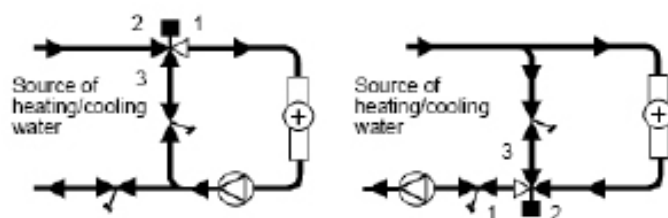

Fig.1

Description		2 way		3 way	
		G1/2-G3/4	G1÷G2	G1/2-G3/4	G1÷G2
Pipe connections	Gas female thread - conical	x	-	x	-
	Gas female thread - parallel	-	x	-	x
Characteristic	EQM	x		-	
	Direct way - modified parabolic plug	-		x	
	Linear angle way	-		x	
Rangeability	50:1	x			
Let-by	Perfect seal	x	-	-	-
	Max Kv % loss	0	0,1%	-	
	Direct way	-		0,05%	0,1%
	Linear angle way	-		0,5%	
Temperature limits ⁽¹⁾	-10T120°C max 1600kPa	x	-	-	
	-10T130°C max 1500kPa				
	-10T120°C max 1600kPa	-	x	x	
	-10T150°C max 1300kPa				
Body	Bronze	x			
Seat	Integral part of the valve body	x			
Plug	Copper alloy	x			
Plug seat	PTFE	x	-	-	-
Stem	Stainless steel	x			
Guide	Bronze	-		-	x
Bonnet	Integral part of the valve body	x			
Gland	Teflon V-ring + EPDM O-ring	x			
Stroke	9,5mm	x	-	x	-
	15,9mm	-	x	-	x

⁽¹⁾ For applications with possible ice formation on stem and gasket, see 248 accessory.

PLANNING OF INSTALLATION

In planning pipework layout the following considerations apply when deciding on the valve position:

- Allow sufficient access for actuator and wiring.
- Avoid plug pointing vertically downwards to avoid risk of condensation or leakage damaging actuator.
- Observe the upper ambient temperature limitation of actuators (50°C).
- Where fluid in valve exceeds 100°C actuator must not be above valve. Therefore valve should be mounted with plug horizontal.
- Observe correct direction of flow through valve as indicated by arrow cast on body.
- Ensure system is efficiently vented, particularly for low flow rates.

INSTALLATION

WARNING - STEAM OR HOT WATER HAZARD. BEFORE REMOVING ACTUATOR FROM VALVE OR OPENING VALVE, ENSURE THAT THE VALVE CONTROL MEDIUM IS ISOLATED AND RELIEVE THE PRESSURE. WORK SHOULD ONLY BE CARRIED OUT BY A COMPETENT ENGINEER.

The system should be thoroughly flushed out to remove foreign matter before fitting the valve. Step-by-step installation instructions are packed with each valve and the precautions listed under 'Planning the Installation' must be observed. Ensure that the valve is fitted in accordance with the direction of flow.

Instructions for fitting electric actuators to valve are packed with actuator.

MAINTENANCE

WARNING - STEAM OR HOT WATER HAZARD. BEFORE REMOVING ACTUATOR FROM VALVE OR OPENING VALVE, ENSURE THAT THE VALVE CONTROL MEDIUM IS ISOLATED AND RELIEVE THE PRESSURE. WORK SHOULD ONLY BE CARRIED OUT BY A COMPETENT ENGINEER.

A periodic check of the valve should be made for general condition and leakage.

ACCESSORY

- 248** Stem heater for applications on -10°C low temperature fluid with MVH and MVE actuators

MAX. DIFFERENTIAL PRESSURE [kPa]

U-Bolt Connection	DN	MVH		MVHA/C*		MVE.06		MVE.10		MVE.15		MVE.22	
		A-AB	B-AB	A-AB	B-AB	A-AB	B-AB	A-AB	B-AB	A-AB	B-AB	A-AB	B-AB
2TBB 3TBB	1/2"	1600	1600	1600	1600	1600	1600	1600	1600	1600	1600	1600	1600
	3/4"	1600	1600	1600	1600	1600	1600	1600	1600	1600	1600	1600	1600
	1"	1600	1600	1320	1170	1130	970	1600	1600	1600	1600	1600	1600
	1 1/4"	1600	1560	840	730	710	610	1220	1120	1600	1600	1600	1600
	1 1/2"	1150	1080	570	500	490	420	840	770	1280	1210	1600	1600
	2"	640	600	320	280	270	230	460	420	710	670	1061	1021

100kPa = 1bar = 10m_{H₂O}

* MVH.A in emergency valve closed, MVH.C in emergency valve open.

MAX REGULATION DIFFERENTIAL PRESSURE [kPa]

The max regulation differential pressure, it means the pressure which can be used during the stroke, is conditioned by wear between seat and plug and by the performance guaranteed by the actuator for the evaluated valve. So we recommend not to overcome the differential pressure whose value corresponds to the minimum between 200kPa (maximum admitted value not to cause wear) and the one shown in the previous table (max close-off differential pressure).

Note: The max operating pressures at different temperatures for various PN classes must correspond to the following standards: UNI 1092-02 and UNI 12516-1.

DIMENSIONS [mm]

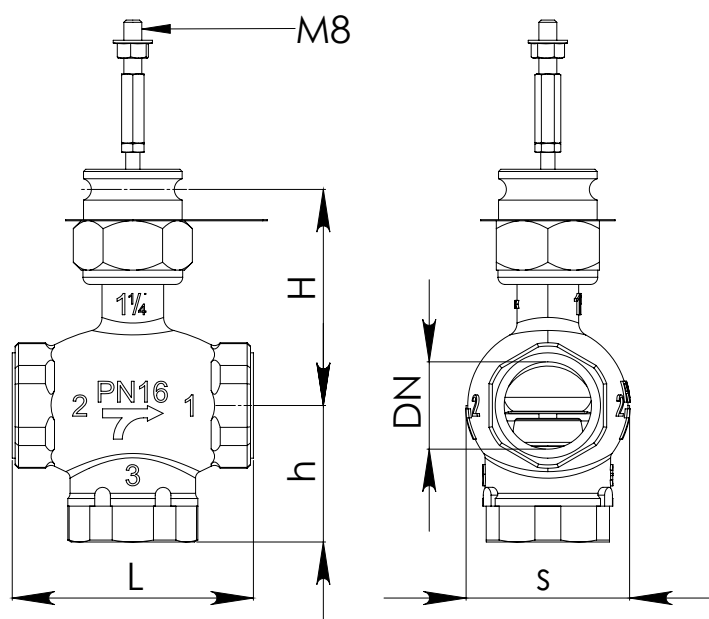

DN	H [mm]	h [mm]		L [mm]	s [mm]
		2 way	3 way		
1/2"	87	38	47	62	44,5
3/4"		40	41	74	
1"	92	66	74	97	51
1 1/4"	97	61	73	108	72
1 1/2"	100	74	74	121	77
2"	108	76	88	144	94

The performances stated in this sheet can be modified without any prior notice