

## Globe Valves Actuators with Emergency Fail Safe Function

MODEL	FORCE [N]	POWER SUPPLY	DESCRIPTION
MVE504R-2-RS	400	24 V AC/DC	Long yoke, modulating
MVE506R-2-RS	600		
MVE510R-2-RS	1000		
MVE515R-2-RS	1500		
MVE504SR-2-RS	400	24 V AC/DC	Short yoke, modulating
MVE506SR-2-RS	600		
MVE510SR-2-RS	1000		
MVE515SR-2-RS	1500		



### APPLICATION AND USE

MVE5xxxR-2-RS is an intelligent device equipped with 2 temperature inputs and with RS-485 (Modbus-RTU) network connectivity for Supply&Return and DeltaT control and limitation as well as for integration with the Building Management System (BMS).

The actuator is endowed with an electronic emergency return function which operates through the use of ultracapacitors whose life is about 10 years if the actuator operates within the operation limits declared in this data sheet.

The emergency position (retracted or extended stem) is set through the use of a jumper which can be easily reached (look at paragraph “DIP switches and jumper settings”) or via Modbus command.

The actuator is supplied with totally discharged ultracapacitors and at its first start a pre-charge phase of 130s max will be necessary. N.B.: in this condition during the first 20-30s no LED signal on the upper ultracapacitors control board will be revealed; when this interval has elapsed the RED LED will power on (ultracapacitors charging phase, look at table on page 11).

During this phase all the functions of the actuator are inhibited and the charge status of the ultracapacitors is signalled through 2 LEDs (look at paragraph “Standard LEDs behaviour”).

Furthermore, MVE5xxx-2-RS can be connected to 2 temperature sensors for the supply and return of a hydraulic circuit for the purpose of simple monitoring or actual control. The actuator is therefore able to implement a temperature control loop independently of the controller with significant savings in terms of hardware (eg. controllers with less I/Os, more compact electrical panels) and field wiring.

MVE5xxxR-2-RS is designed for the control of two and three way globe valves usable in:

- heating and air conditioning systems;
- air handling units;
- district heating plants;
- industrial control systems.

The actuator can be controlled by a Modbus RTU (master) device via an RS-485 communication bus as well as by a proportional (modulating) command signal or by a floating signal.

The installation of MVE5xxx-2-RS is quick and easy thanks to the U-Bolt type connection and self-diagnosis functions guarantee correct and error-free installation. It can be mounted on all types of iSMA CONTROLLI flanged valves, while connection kits are available for iSMA CONTROLLI threaded valves and valves from other manufacturers (table on page 3).

The actuator has a very high resolution (500 steps over the entire stroke range) for precise control of the fluid temperature and is able to self-calibrate on different strokes without requiring user action.

MVE5xxx-2-RS is also equipped with a USB port for local configuration and diagnostics. When USB cable is connected, the motor can't move.

The performances stated in this sheet can be modified without any prior notice.

## TECHNICAL CHARACTERISTICS

DESCRIPTION		MVE504R-2-RS MVE504SR-2-RS	MVE506R-2-RS MVE506SR-2-RS	MVE510R-2-RS MVE510SR-2-RS	MVE515R-2-RS MVE515SR-2-RS
Supply voltage L1 Ln		AC: 24 V AC $\pm 20\%$ 50-60 Hz DC: 22-30 V DC (Reference Ln)			
Power consumption	Running	10 VA/4,5 W	13 VA/6 W	18 VA/8 W	21 VA/11 W
	Holding	8 VA/4 W	11 VA/5 W	11 VA/5 W	13 VA/7 W
	Charging phase	32 VA/18W			
Ultracapacitors charging phase (if totally discharged)		130 s			
Running time	Emergency return phase	1,1 s/mm			
	Modulating	16 s @ 45 mm			
Transformer Size [VA]		20	50	60	80
Stroke		5-60 mm (limited to 30 mm for MVE.SR-2-RS)			
Force		400 N	600 N	1000 N	1500 N
Duty cycle		Max 50%/60 minutes			
Analogue input Y M		Voltage 0-10 V DC - impedance > 100 k $\Omega$ (range: 0-10 V DC, 2-10 V DC, 0-5/2-6 V DC, 5-10/6-10V DC) 500 $\Omega$ (range 4-20 mA)			
Output V+		Voltage 16 V DC $\pm 0,5$ V DC; max load 25 mA			
Output U		Voltage 2-10 V DC (0-100%); max load 2 mA			
Cycles number of manual action		6.000			
Cycles number of automatic action		100.000			
Type of action		Type 1			
Type of movement		Linear			
Room temperature		Operation -10T55°C; storage -20T55°C			
Room Humidity		Max 90% R.H.			
Protection degree		Nema 2 (*) / IP54 (**)			
Insulation class		III			
Printed Circuit Board		FR4 (material), PLC (Performance Level Categories) = 3, PTI (Proof Tracking Index) = 175 - 249 V CTI (Comparative Tracking Index) = PTI, Pollution Degree = 2			
Standard		Emission/Immunity EMC 2014/30/UE according to EN 61326-1:2013 standard			
Material		Housing: aluminium - cover: ABS plastic			
Colour		Aluminium / white			
Weight [kg]		1,7 (MVE5xxR-2-RS); 1,6 (MVE5xxSR-2-RS)			
Date code		yy/ww			

### \*To guarantee "Nema Type 2" protection:

- use flexible metal conduit (not supplied);
- Push the listed conduit fitting device (PG13,5 - not supplied) over the actuator's cable to butt against the enclosure. Screw in conduit connector. Jacket the actuators input wiring with listed flexible conduit. Properly terminate the conduit in a suitable junction box.

### \*\*To guarantee IP54 protection

- Insert the actuator cable in the PG13,5 cable gland (not supplied).

## OPERATION

MVE5xxxR-2-RS is equipped with a modern brushless direct current motor that drives a gear train and converts engine revolutions into accurate and repeatable linear movements on the valve stem.

MVE5xxxR-2-RS can be controlled by 2 types of signal:

- Modbus command;
- modulating (or proportional) with selectable range (e.g. 0-10 V DC, 2-10V DC, 0-5 / 2-6 V DC, 5-10 / 6-10 V DC and 4-20 mA).

The control mode can be set via Modbus, via USB or via the dip-switches (only 0-10 V DC, 2-10 V DC and 4-20 mA are selectable) on

the board. All settings and configurations can be done over the RS-485 network or USB connection by the free-of-charge software MVE-2-RS Configurator as well as by the BMS over the RS-485 network. Modbus Registers description is available in Product Manual DMP283en.

## FUNCTIONS AND SETTINGS

### Diagnostics

The actuator is equipped with a self-diagnostic algorithm capable of detecting the following conditions/anomalies:

- actuator status (Normal Operation, Calibration, Initialization, Fault, Manual).
- Calibration attempt on a stroke not in the range 5-60 mm.
- Unexpected stall (e.g. valve blocked or extra stroke due to actuator not correctly coupled); the number of detected events is stored permanently.
- Supply voltage outside the allowed range; the number of detected events is stored permanently.
- Total number of opening and closing cycles.
- Temperature sensors outside the allowed temperature range (if any).

All this diagnostic information is available through dedicated Modbus registers and can be read by the Supervision system (BMS). Diagnostic data is also available via the USB connection.

Furthermore, the anomaly conditions are locally shown by means of two green and red LEDs on the board which are suitably flashing(see table on page 9).

### Temperature control loop

MVE5xxxR-2-RS can be connected to 2 sensors for measuring the supply and return temperature of a hydraulic circuit for monitoring purposes or for control purposes.

The actuator can implement a temperature control loop (PID): the actuator independently controls the supply or return temperature according to a set-point provided by the supervisor system; the BMS only sets the temperature setpoint and the actuator works independently even in the absence of the Modbus connection.

If only a temperature monitoring activity is required, the measured values are made available to the BMS through dedicated Modbus registers. Temperature setpoints, PID control parameters, Heating/Cooling mode can be set via Modbus or via USB.

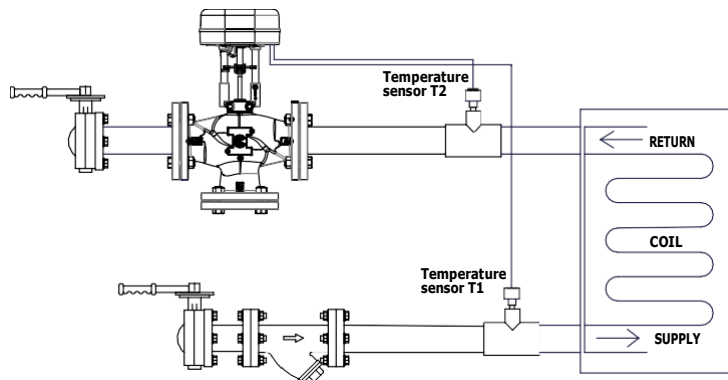

$\Delta T$  control loop (water heating example)

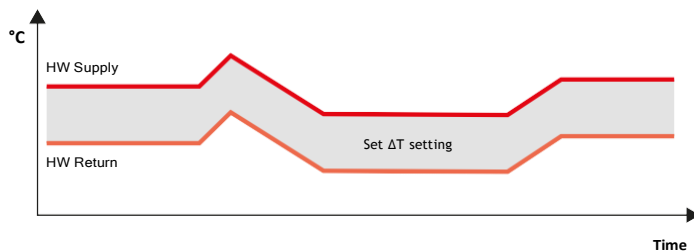

T Return control loop (water heating example)

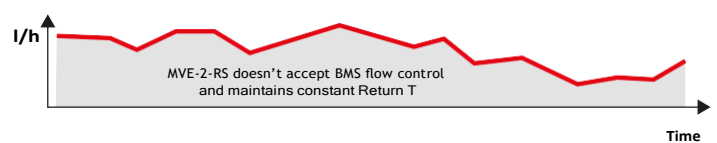
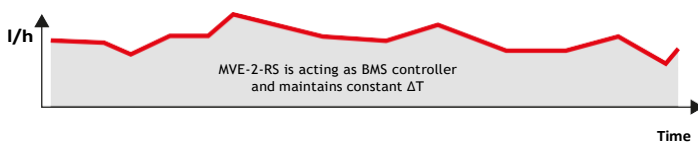
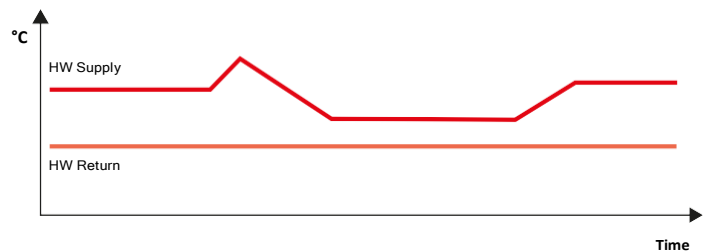

### Delta T limit function

If a heating or cooling system works with a differential temperature between the supply and return too low, it means that there is no heat exchange between the fluid and the environment and therefore it is convenient to reduce the flow rate as this does not generate any heating or cooling effect. This means that the pumps circulate too much water with unnecessary increase of energy consumption. The Delta T limit function automatically

limits the flow rate to prevent the Delta T level from falling below the desired differential

temperature.

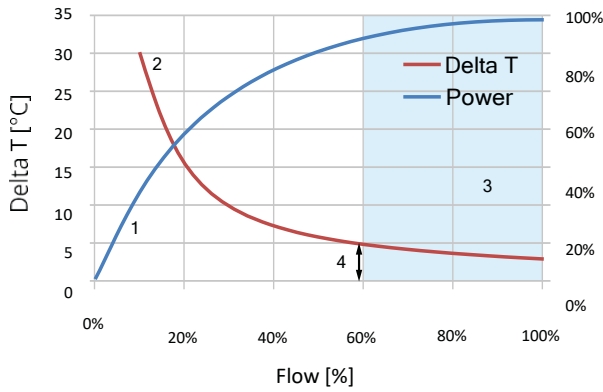

- 1 – Power output of the heating or cooling coil
- 2 – Diff. temperature between supply and return
- 3 – Loss zone (heating or cooling coil saturation)
- 4 – Adjustable minimum differential temperature

This function overrides the control signal from the BMS when the DeltaT is lower than the setpoint; BMS will be again in charge of the valve positioning when the deltaT is higher than the setpoint.

The minimum value of Delta T and the other parameters of the control loop (PID) can be set via Modbus or via USB.

Min ΔT limitation (water cooling example)

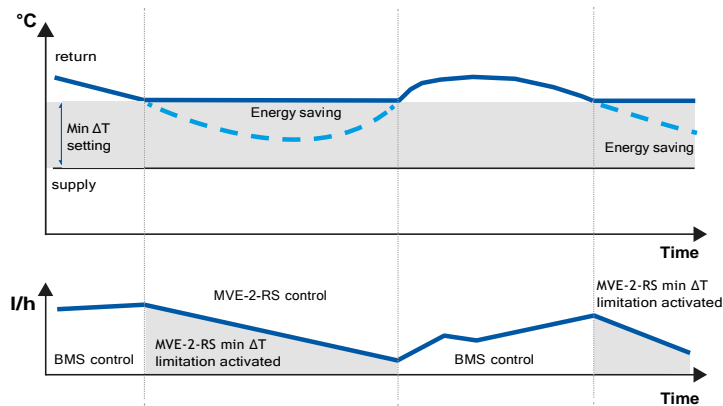

Supply/Return temperature limit function

MVE2xxx-2-RS can implement a limit control loop on the return temperature or on the supply temperature in order to override the BMS control when energy efficiency conditions are not respected (e.g. in cooling mode return temperature higher than a setpoint value). The following limiting functions can be implemented:

- Maximum temperature limit control loop: the actuator will override the BMS control signal when the supply \return temperature is higher than the setpoint; the user can select if the loop has to be implemented on the supply or return temperature sensor. For example in a domestic hot water application the acuator can override the bms control signal if the supply temperature exceded a setpoint value that could be dangerous for the user.
- Minimum temperature limit control loop: the actuator will override the BMS control signal when the supply \return temperature is lower than the setpoint; the user can select if the loop has to be implemented on the supply or return temperature sensor. For example in a cooling application the actuator can override the BMS control signal if the return temperature is lower than a setpoint value in order not to affect the chiller efficiency.

Max T Supply limitation (water heating example)

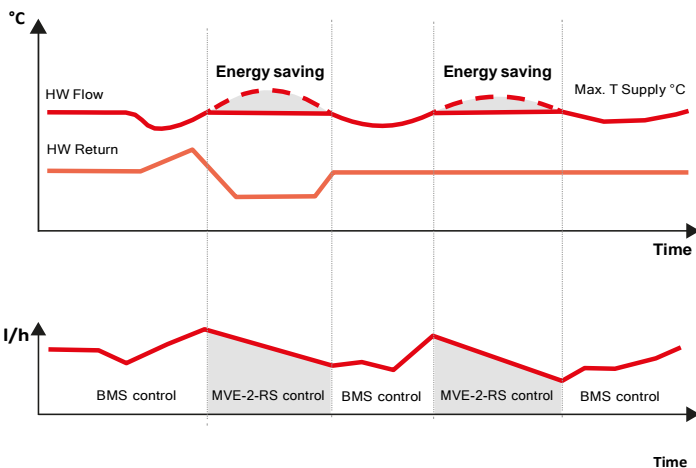

Min T Supply limitation (water cooling example)

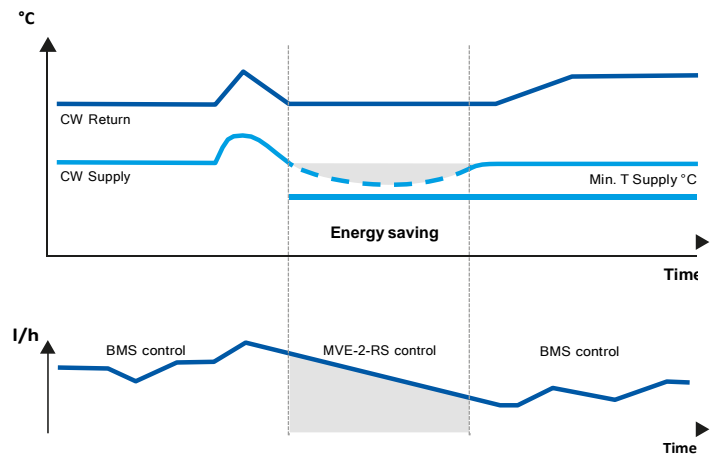

### Max T Return limitation (water heating example)

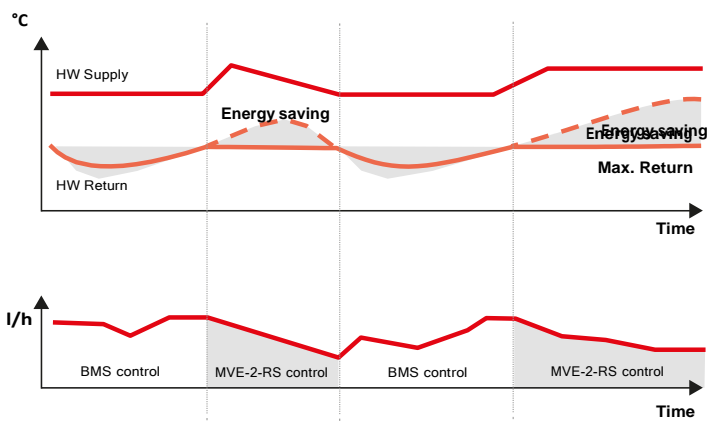

### Min T Return limitation (water cooling example)

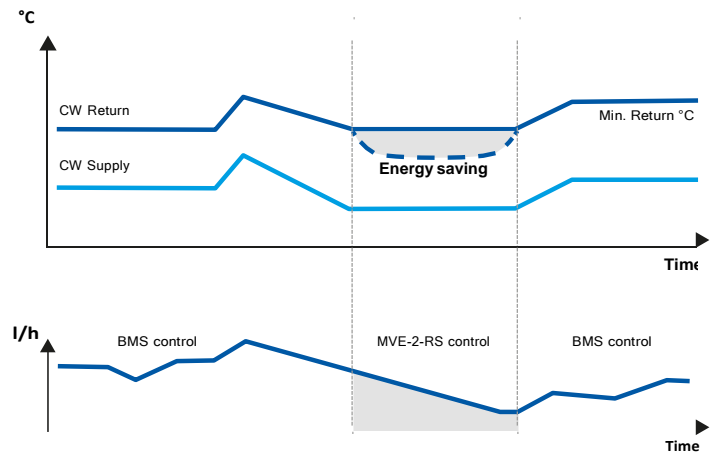

### Manual Override

There is a manual operation handle on the actuator. When it is low the manual override is engaged and the valve can be manually positioned. The manual override handle stays in position until it is raised again, then board and motor will be powered again. When the manual override is engaged the GREEN and the RED LED are ON. Manual operation handle can also be used to modify any DIP switch setting or as reset function after any alarm occurrence.

### Position Feedback

The current position of the actuator is made available via Modbus (0-100%) as well as via a 2-10 V DC analog signal.

### Calibration function

MVE5xxxR-2-RS is equipped with an automatic calibration function.

The plug & play function enables the calibration at the first start-up of the actuator and therefore no further calibration operations are required unless maintenance is required on the valve or particular alarm conditions occur. If it is necessary to repeat the calibration, it can be activated by pressing the S2 button on the electronic board or remotely via Modbus.

### Installation instructions

Position the valve stem at the end of its travel, slide the actuator onto the valve bonnet; adjust the position of the actuator with the manual control so that the square nut on the valve stem fits perfectly with the slot on the connection plate. Slide the U-shaped bolt into the groove of the valve bonnet and secure it with the nuts.

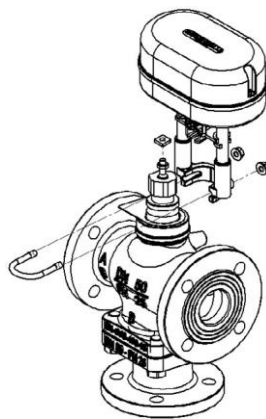

For further details see the Assembly Instructions (MVE5xxxR-2-RS\_DIM336en).

### MAINTENANCE

The actuator is maintenance-free.

### ACCESSORIES

<b>GMVE</b>	Thermal insulation for MVE actuators *
<b>GMVES</b>	Thermal insulation for MVE.S actuators *
<b>iSMA-B-CVT-RS485</b>	USB to RS485 Converter, USB 1.0 and 2.0 compatible, built-in: status LEDs, switchable terminating resistor, EEPROM memory. Communication over 3-wire bus. The miniUSB to USB cable is not included.
<b>PA</b>	1/2" M Immersion sensor pocket pair, length 45 mm, internal $\varnothing$ 6 mm
<b>PB</b>	1/2" M Immersion sensor pocket pair, length 85 mm, internal $\varnothing$ 6 mm

\* It is not possible to install both thermal insulation (Gxxxx) and stem heaters.

**COMPATIBLE VALVES AND ACTUATORS**

iSMA CONTROLLI VALVES	MVE5.R-2-RS	MVE5.SR-2-RS
Current iSMA CONTROLLI valves	•	-
VSXT09PBP, VSXT10PBP	-	only with MVE504S-2-RS
2-3TGB.F PN16	-	•
iSMA CONTROLLI valves with threaded M40 connections (except for VSB-VMB, VSB.F-VMB.F PN16)	with AG51	-
VSB-VMB, VSB.F-VMB.F PN16	with AG52	with AG63
OTHER MANUFATURERS VALVES	MVE5.-2-RS	MVE5.S-2-RS
Belimo H2..X-S e H3..X-S	with AG82	with AG82
Siemens *	with AG70-10 with AG70-14	-
Danfoss (VR/VF (S) models)	with AG60-07	-
TAC DN15-V298	with AG60-08	-
TAC DN15-V2XX/V3XX	with AG60-09	-
Honeywell **	with AG60-10	-
Airtek	with AG60-11 with AG60-12	-
Johnson Controls VB7816-2111	with AG66	-
Johnson Controls BM-3018-3300	with AG67	-
MUT MK DN50-150	with AG69	-
Tac Venta	•	-

\* AG70-10 for valves having stem Ø 10mm, AG70-14 for valves having stem Ø 14mm

\*\* valid for the following models: M6: V176A,B, V538C, 1/4": V5011A

**ELECTRICAL CONNECTIONS**

Remove the cover screw with a screwdriver and then remove the cover as shown in the picture beside. The actuator is equipped with 3 removable terminal block:

- a removable 8-poles terminal block (T1) with power supply, analog and digital command signal and feedback signal; each terminal pole is clearly marked and the same label is shown on the electronic board. Before turning on the actuator, make sure that the terminal block is correctly connected to the board and that the label on the terminals and board match;
- a removable 6-poles terminal block (T2) dedicated to the RS-485 bus connection (Modbus) - (only 3 poles are used);
- a removable 6-poles terminal block (T3) dedicated to the connections of the temperature sensors (only 4 poles are used).

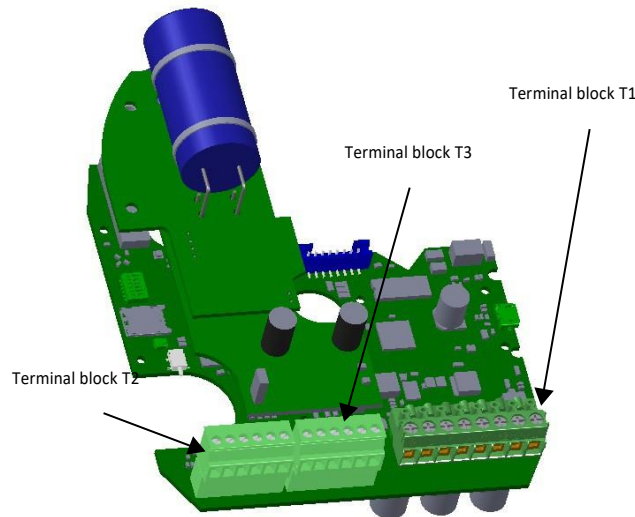

The actuator is supplied with 2 cable glands with die-cut membranes for safe wiring.

- Cable gland 1 for 3 cables: 2-wires cable for power supply; 5-wires cable for control and feedback signals and 3-wires cable for Modbus;
- Cable gland 2 for 4 cables: 2-wires cable for T1 temperature sensor, 2-wires cable for T2 temperature sensor.

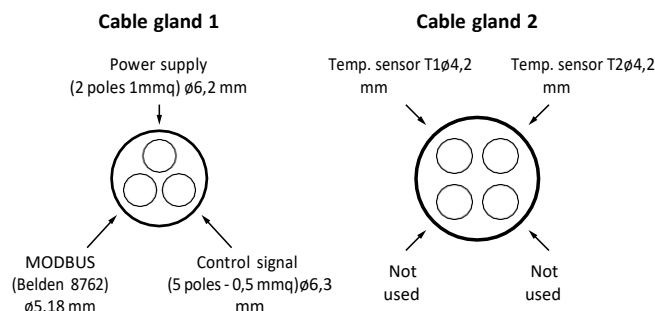

### Terminal block T1

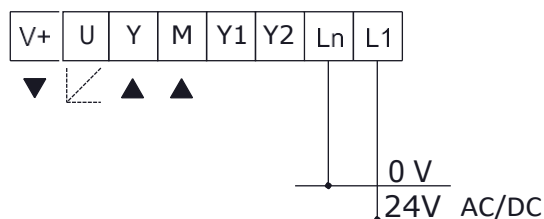

LABEL	DESCRIPTION	FUNCTION	CABLE TYPE	MAX WIRE LENGTH
L1	24 V AC/DC	Power supply	AWG 16 (min 1mm <sup>2</sup> - max 1,5mm <sup>2</sup> )	75 m
Ln	0 V			
Y	0-10 V DC	Modulating control input	AWG 20 (min 0,5mm <sup>2</sup> - max 1,5mm <sup>2</sup> )	200 m
M	0 V (common)			
Y1	Not used			
Y2				
V+	16 V DC	Voltage output max 25 mA	AWG 20 (min 0,5mm <sup>2</sup> - max 1,5mm <sup>2</sup> )	200 m
M	0 V (common)			
U	2-10 V DC	Feedback output signal	AWG 20 (min 0,5mm <sup>2</sup> - max 1,5mm <sup>2</sup> )	200 m
M	0 V (common)			

### Terminal block T2

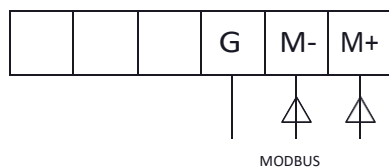

LABEL	DESCRIPTION	FUNCTION	CABLE TYPE	MAX WIRE LENGTH
M+	Tx	Modbus connection	Belden 8762	See chapter Modbus – RS485
M-	Rx			
G	Shield			



**Terminal block T3**

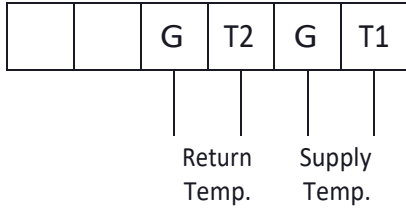

LABEL	DESCRIPTION	FUNCTION	MAX WIRE LENGTH
T1	Supply temp. sensor	Temperature control loop and $\Delta T$ limit function	10 m
G	Common		
T2	Return temp. sensor		
G	Common		

**Wiring diagrams**

**Modbus control**

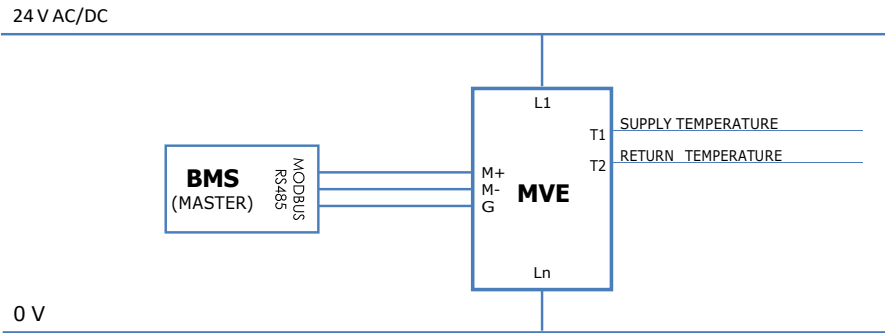

**Modulating Control & Modbus Supervisory**

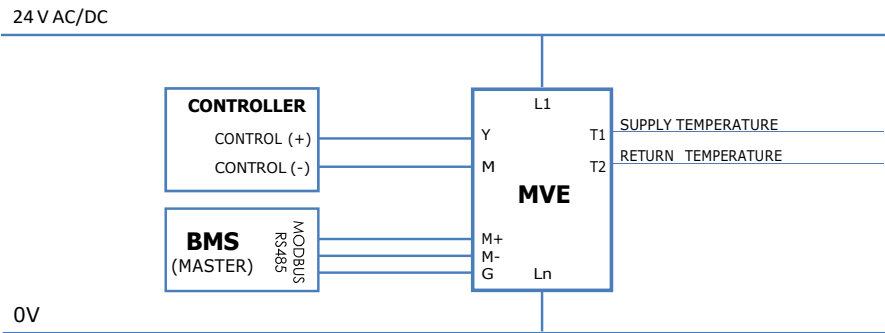

**Modbus – RS485 connection**

RS485 network is made with a 3-conductor cable, which will be recognized below with “+” (M+), “-” (M-) and “GND” (pin G). For wiring, we recommend the Belden® cable, model 8762. In particularly “noisy” environments, we recommend the Belden® cable, model 3106A connecting the twisted pair respectively to the “+” and “-” signals, the reference conductor to GND and the screen on the ground.

Alternatively, a cable with the following electrical and mechanical characteristics can be used: AWG 20/22; characteristic impedance of 120Ω; with copper conductors, of the “braid” type, twisted; with braided shielding and protective insulation.

The shield must be connected to the GND signal (pin 25) of the actuator.

The network must only be wired according to the following principle, defined as a “daisy chain” (the device consists of a single RS485 port). Star connections are not allowed.

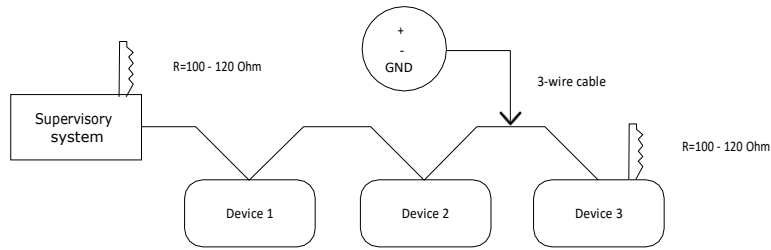

### Connection warnings

For correct wiring of the network it is recommended to respect the following warnings:

1. Do not use different types of cable to create the same network, but always and only use the same type of cable;
2. The network cable is crossed by SELV safety voltage signals and must not be wired in channels intended for cables with dangerous voltages (for example 230Vac) or carriers of high currents, especially if in alternating current. Also avoid parallel paths to these power cables;
3. Wire the cable as straight as possible, avoiding folds with tight bending radius, let alone wrapping it in unnecessary charges;
4. Do not twist the cable around power conductors and, if you have to cross them, provide a 90 ° cross between the cable and these conductors;
5. Keep away from electromagnetic field sources, in particular from large motors, switchboards, neon ballasts, antennas of all types;
6. Avoid that the pull tension of the cables exceeds 110N (11.3 kg) to prevent ironing;
7. Evaluate the route in advance so as to shorten it as much as possible and take note of the addresses of the instruments connected with particular reference to their location in orderly sequence. This can be very useful in maintenance; We recommend that you take note of the Modbus address and report it on the product label in the space provided for it.
8. Do not invert the polarity "+" and "-" at the connection terminals;
9. Avoid short pieces of cable in the connection terminals to the instruments, in order to allow a possible maintenance without tearing or pulling of the cable itself;
10. Identify the start and end terminations and avoid "open" segments; Termination resistors and network polarization The slew-rate control, common to all our converters, and the baud rate limited to 9600 baud (bit/sec) make termination resistors unnecessary. The RS485 network requires polarization typically borne by the Master device; the regulator does not have polarization resistors. The transceiver used by the actuator allows to drive up to 256 knots.

The RS485 standards provide for a maximum length of 1200 m and/or 32 devices on the network. However, it should be noted that the more the "standard" limits are exceeded (maximum limit of 32 devices or cable lengths greater than 1200 m), the higher the probability that communication problems will arise. The phenomenon is not systematic and may not even occur.

Vice versa, if it occurs, and none of the points indicated in this paragraph has allowed to solve the problem, the connection of a repeater (code CONV-RS485-RIP) is suggested, as shown in the figure below:

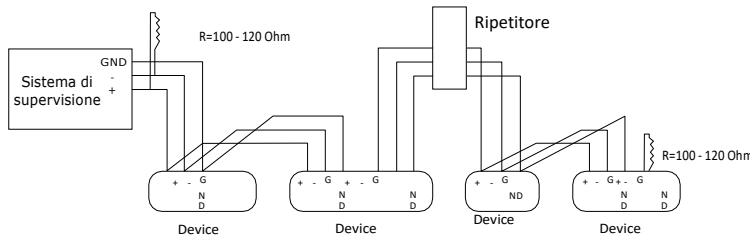

**NOTE** - Use a repeater if the cable length exceeds 1200 m or if there are more than 32 devices.

### DIPSWITCH SETTING

Set the DIP switches according to the tables here below. In order to be sure that any modification has been accepted by the actuator, power down and power up it again or act on the manual operation handle to be sure that settings will be recognized.

**DEFAULT SETTINGS**

ON	REV	DIR	MOD	NORM	FIRMWARE	0-10	2-10	4-20 mA
OFF	1	2	3	4	5	6		

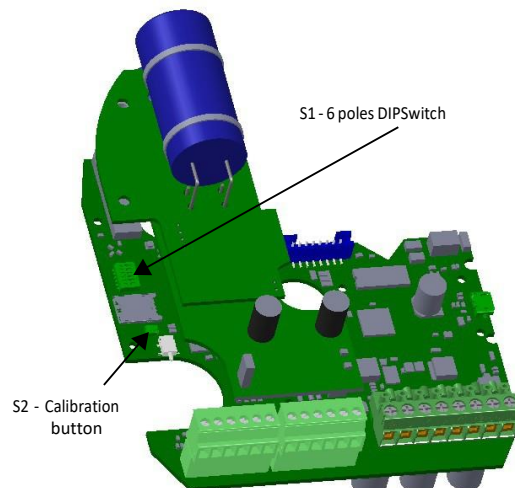

Jumper for emergency return position selection (open jumper - totally retracted joint; closed jumper - totally extended joint)

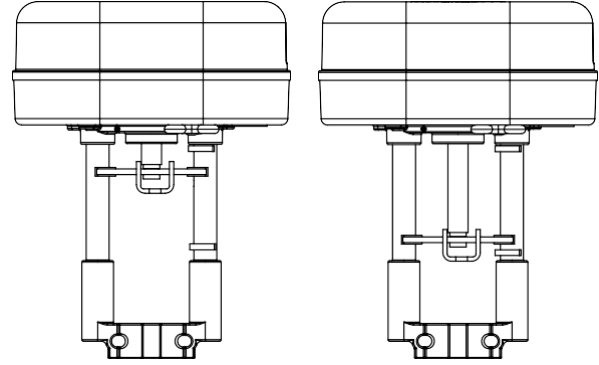
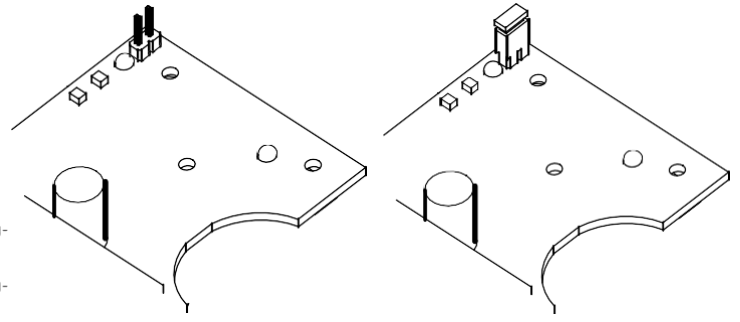
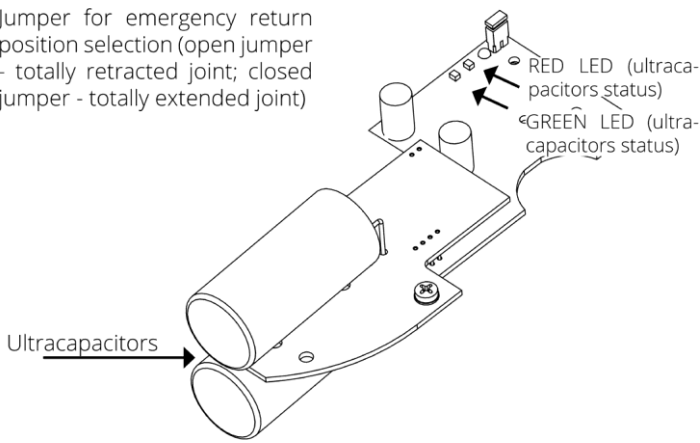

Open jumper retracted joint

Closed jumper extended joint

DIP SWITCH	OFF	ON
1	<p>Direct action</p> <p>U = feedback</p> <p>U = 2V</p> <p>U = 10V</p>	<p>Reverse action</p> <p>U = feedback</p> <p>U = 10V</p> <p>U = 2V</p>
2	<p>Modulating Control (MOD) (Input between Y [+] and M [-])</p>	Not used
3	-	Enter in bootloader (Firmware download)
4	Modulating Control 0-10 V DC (DIP n. 2 OFF only)	Modulating Control 2-10 V DC (DIP n. 2 OFF only)
5	Not used	Not used
6	Voltage Input Signal (input between Y [+] and M [-])	Current Input Signal 4-20mA (input between Y [+] and M [-])

## DIAGNOSTIC - ALARM FUNCTIONS

N°	ERROR TYPE	ACTUATOR STATUS	ACTUATOR BEHAVIOR	NOTIFICATION TYPE	POSSIBLE ANOMALY	RESTORE PROCEDURE
				LEDS		
1	Stroke less than 5 mm	Calibration / first installation	The actuator returns to its initial position and does not respond to the command. The actuator keeps the previous stroke or the default stroke	RED ON	Valve with stroke less than 5 mm	Remove power and re-power again
2	Stroke greater than 60 mm	Calibration / first installation	The actuator leaves the maximum range of 60mm and moves to the new extreme. Once the new stroke limit is reached, it returns to the initial position signaling an anomaly. The actuator does not learn the new stroke.	RED fast blinking + GREEN ON	Valve with stroke greater than 60 mm or incorrect coupling	Remove power and re-power again

N°	ERROR TYPE	ACTUATOR STATUS	ACTUATOR BEHAVIOR	NOTIFICATION TYPE	POSSIBLE ANOMALY	RESTORE PROCEDURE
				LEDS		
3	Unexpected collision within the stroke	Normal operation	The actuator checks the stall condition 5 times. At the end of the attempts it signals an anomaly. The actuator does NOT learn the new stroke, but after 60s repeats the attempts to check the blocking conditions	RED fast blinking	Valve blocked	Reverse the control signal
4	Stroke greater than expected	Normal operation	The actuator moves to the new crash position with low speed signaling an anomaly. The actuator does NOT learn the new stroke	RED fast blinking	Damaged valve or incorrect coupling	Reverse the control signal
5	Low supply voltage	Normal operation	The actuator continues to operate but performance is not guaranteed. If the low voltage events persist (events greater than 10), the actuator stops working.	RED blinking alternately fast (5sec) and slow (5sec) + GREEN ON	1. Wrong sizing of transformer 2. Unstable power supply	Check and restore power
6	High supply voltage	Normal operation	The actuator continues to operate but performance is not guaranteed. If the high voltage events persist (events greater than 10), the actuator stops working.	RED slow blinking	1. Wrong sizing of transformer 2. Unstable power supply	Check and restore power
7	Temperature sensors error	Normal operation	Temperature or $\Delta T$ regulation loops not working	RED blinking alternately fast (5sec) and slow (5sec) + GREEN ON	1. Incorrect temperature probe connection 2. Temperature probes damaged 3. Temperature detected outside the range of use	Check the connection and the condition of the temperature sensor

## STANDARD LEDES BEHAVIOUR

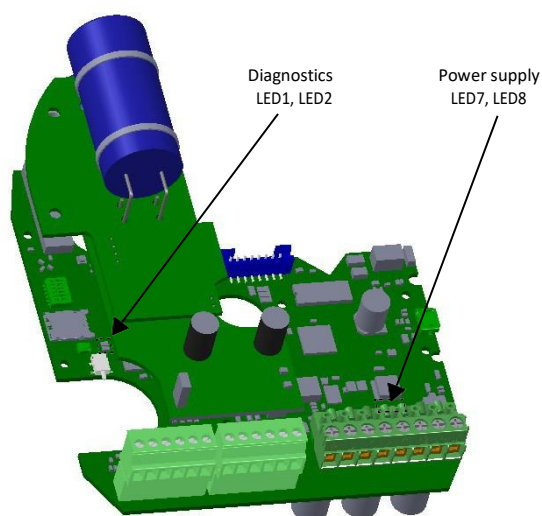

N°	LED 1 AND 2	ACTUATOR STATUS
1	FIXED GREEN	Actuator at end point of the calibrated stroke
2	GREEN SLOW BLINKING	Actuator has arrived or is moving towards an intermediate point of the calibrated stroke
3	RED and GREEN BLINKING ALTERNATIVELY	Actuator is calibrating the stroke or performing the initial positioning
4	RED and GREEN FIXED	Manual control activated, the actuator ignores the control signal. WARNING! The board is powered
5	RED FIXED	Charging phase of the supercaps in progress
6	RED and GREEN BLINKING SIMULTANEOUSLY	Actuator is in the emergency return phase

N°	LED 7 (RED) AND 8 (RED)	ACTUATOR STATUS
1	LED 7 RED ON; LED 8 RED ON	Stable power supply of the actuator
2	LED 7 RED ON; LED 8 OFF	Unstable actuator power supply; possible hardware problem

#### Upper electronic board

LED	ULTRACAPACITORS STATUS
GREEN	Ultracapacitor charged
RED	Ultracapacitor discharging
OFF	Ultracapacitor totally discharged

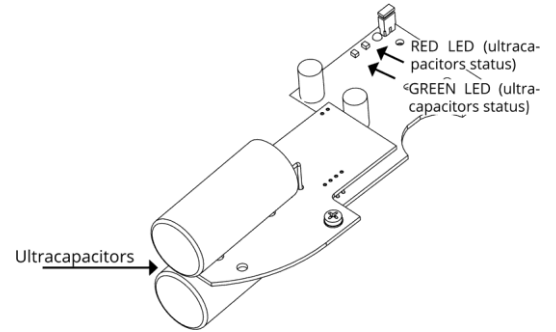

#### DIMENSIONS [mm]

##### MVE5xxR-2-RS

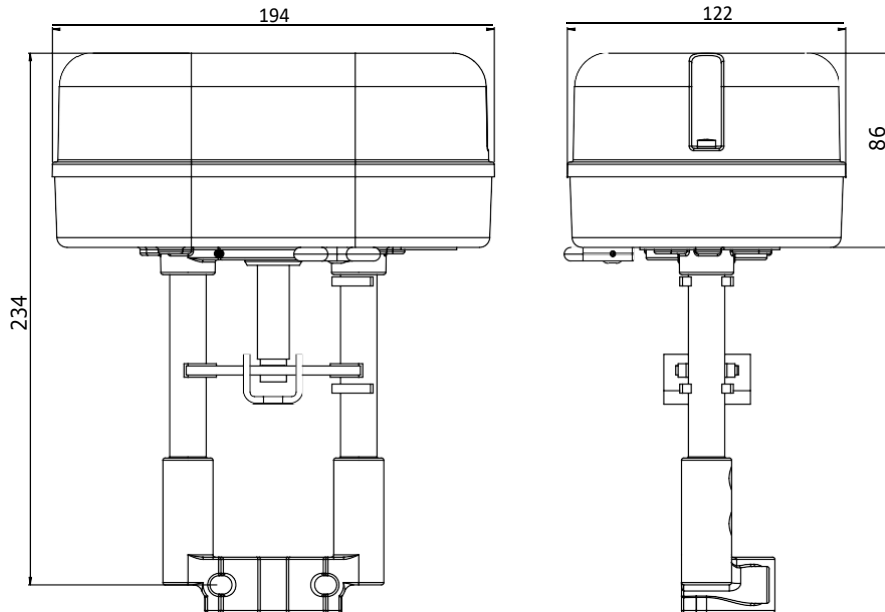

##### MVE5xxSR-2-RS

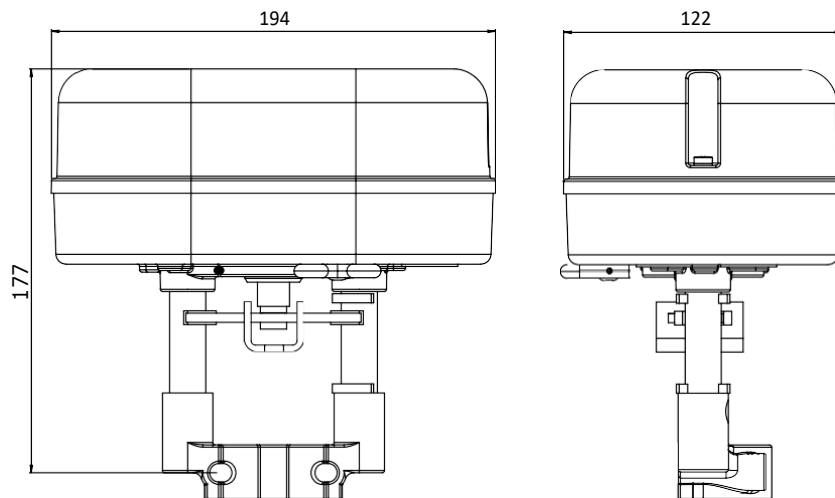

QUICKLINK SOLUTIONS S.r.l. | [info@qlsol.com](mailto:info@qlsol.com)

North West Office: Via G. Matteotti 193-203, 21044 Cavarina con Premezzo (VA), Italy

North East Office: Via F. Petrarca, 34, 35020 Albignasego (PD), Italy