

Compact actuator for globe valves

MODEL	CONTROL SIGNAL	POWER SUPPLY	MAX. STROKE
MVC203	3 Point - ON/OFF	230 Vac	16 mm
MVC403		24 Vac	
MVC503	Proportional		



APPLICATION AND USE

MVC actuator can be used with valves push/pull (using auto stroke calibration) or with valves with spring return using fixed stroke to control hot/cool water flow rate in two/four pipes terminal units, zone and solar plants, small reheating and dehumidification coils.

OPERATION

MVC is an electrical bidirectional actuator. The valve stem is activated through a synchronous motor and a gear train optimised in order to have high performances and minimal noise ejections. The actuator is equipped with a movement of limit force which is able to stop the power supply when the force of 300N is reached. If configured as auto calibration stroke, the software of the proportional models enables the stroke calibration, so it can be used on any valve, as long as it respects the maximum stroke limit allowed (look at the above table).

Moreover proportional models are equipped with 3 LEDs whose operation is explained in the table at page 5.

“MAX STROKE LIMIT” function (only for MVC503 model)

Stroke Limit” function is activated to prevent the escape of the screwjack.

- At startup, the actuator is initialized in the UP position (red-greenyellow LED ON).
- If is controlled downward by control signal, when the maximum stroke is exceeded, it will automatically be repositioned UP. This operation is performed 3 times, then the actuator enters in block mode (yellow LED ON, others OFF).

To reset it, the actuator must be powered down and powered up again.

MVC503 model is proportional and can work with 0-10 Vdc, 2-10 Vdc, 0-5 Vdc and 4-20 mA working fields.

POSSIBLE CONNECTIONS

MVC203, MVC403 e MVC503 are used with iSMA CONTROLLI valves without spring. The actuator has a joint that allows a solid connection to the valve stem. MVC203 and MVC403 models can be connected to any controller with a 3-point control signal that complies with the paragraph “TECHNICAL CHARACTERISTICS”. In case of use of non iSMA CONTROLLI valves please contact technical office for proper adaptor.

The table below shows the compatible valve models:

MODEL	VALVE WITHOUT SPRING				
	VSB.T-VMB.T 3/4" .. 2" stroke 5,5 mm	2-3TGB15B 1/2" stroke 11,5 mm	2-3TBB.T 1/2" .. 2" stroke 12 mm	2TGA.BT 3/4" .. 2" stroke 8,5 mm	VALVES OF OTHER MANUFACTURERS stroke up to 16 mm
MVC203	●	● (AG74-03)	●	●	●
MVC403	●	● (AG74-03)	●	●	●
MVC503	●	● (AG74-03)	●	●	●

The performances stated in this sheet can be modified without any prior notice.

WARNING In case of MVC coupling on a valve produced before September 2019 to replace an MVT, must be used the 55061 kit.

VALVE (production previous September 2019)	ACTUATOR to be replaced	Replacement KIT
VSB.T-VMB.T	MVT203 MVT403 MVT503	55061
2-3TBB.T		
2-3TGB.B		

MANUFACTURING CHARACTERISTICS

The actuator housing is made of a polymeric fireproof material; a metal ring M30x1,5 is dedicated to the assembling with the valve. The actuator is equipped with a cable for electric connection.

SAFETY PRESCRIPTIONS

- Install on the power supply line a protecting device to avoid short circuits (fuse or magneto-thermic) according to the specifications in force;
- in case of accidental removal of the cover and/or of the connector cover, make sure that power is disconnected before working on the actuator or near it;
- the products are maintenance free.

VARIANTS

PS107 actuator with M28x1,5 modified ring nut.

ACCESSORIES

AG74-03 2-3TGB.B valves adaptor (N.B. to be used in replacing of the spindle extension provided with the valves).

55061 Kit of adapters for coupling the actuator with VSB.T-VMB.T, 2-3TBB.T and 2-3TGB.B series valves produced before September 2019.

In case of use of non iSMA CONTROLLI valves please contact technical office for proper adaptor.

TECHNICAL CHARACTERISTICS

CHARACTERISTIC	MVC203	MVC403	MVC503
Power supply	230 Vac ± 10%	24 Vac ± 10%	
Consumption	16,2 VA - 1,1 W	2,2 VA - 2,2 W	3,6 VA - 3 W
Frequency	50/60 Hz		
Stroke timing (50 Hz)	60 s : V.XT, VSB.T/VMB.T, VSB.T/VMB.T, 5,5 mm stroke		
	100 s : 2TGA.B 8,5 mm stroke		
	130 s : 2-3TGB.B 11,5 mm stroke		
Speed	11,5 s/mm at 50 Hz - 9,4 s/mm at 60 Hz		
Force	300 N (UNI 9497: 1989)		
Operation temperature	-5T55 °C		
Storage temperature	-25T65 °C		
Protection class	II (IEC 60950-1: 2005)		
Connection cable	3 wire 1,5 m		5 wire 1,5 m (CEI 20-22/II)
Protection degree	IP54 (CEI EN 60529: 1997)		
Weight	0,25 Kg		
Feedback signal	-		2-10 V (2 V fully retracted in direct action or 2V fully extended in reverse action)
Manual override	Operable with 3 mm hex key		
Reference Directives and Standards	EMC 2014/30/UE according to EN 61326-1: 2013. LVD 2014/35/UE according to EN 61010-1: 2010 for MVC2xx.		

INSTALLATION AND ASSEMBLING

Mount the actuator on the valve screwing in the ring nut M3x1,5 without locking it; using the manual override make the set-screw go down until to align the actuator spindle slot with the locknut (A), secure with the bolt (B) through not threaded hole in locknut (B).

Direct the actuator in the desired position and lock the ring nut M30x1,5.

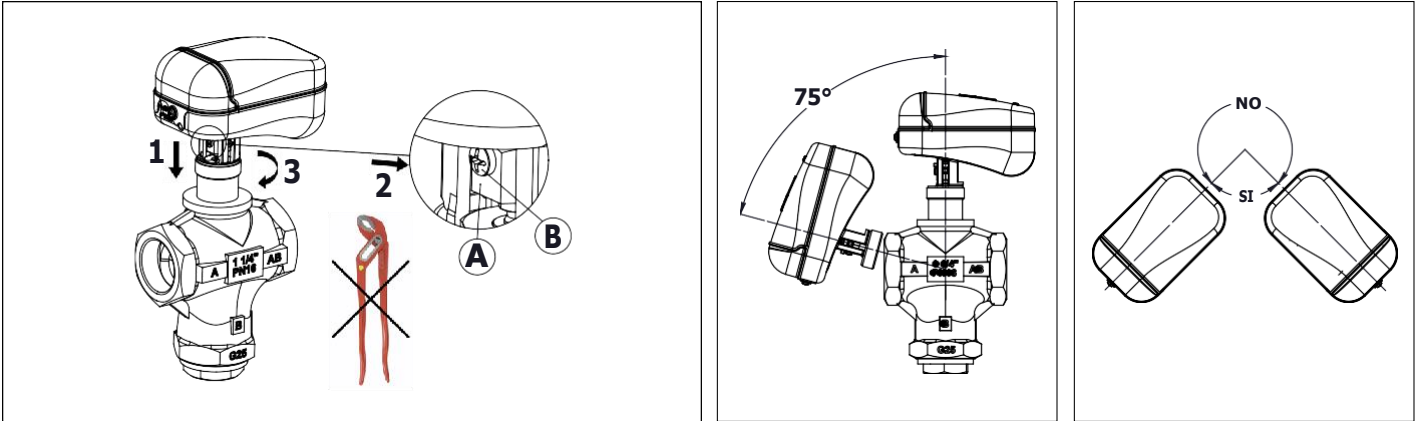

WIRING DIAGRAMS

Make the electrical connections in compliance with the regulations in force. To check the direction of movement of the pusher, compare the direction of rotation of the manual override with the indication on the base. The movement of the valve stem, it can also be observed through the slots in the fixing ring.

MVC 3 point connection

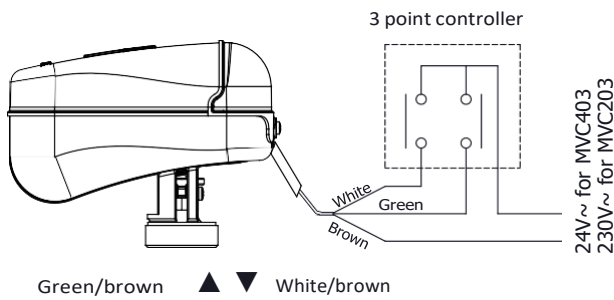

MVC proportional connection

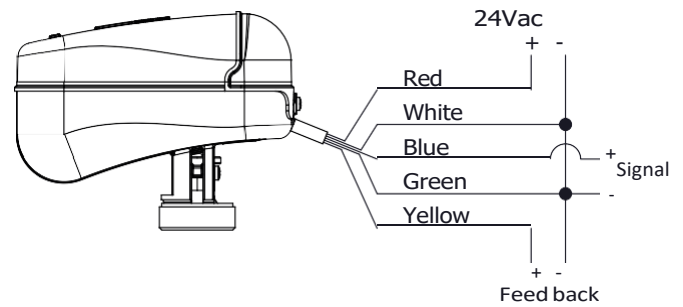

ON/OFF connection with external relay

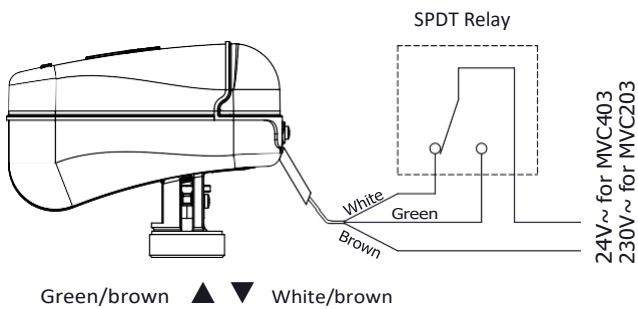

SETTINGS AND FUNCTIONS (ONLY MVC503 MODEL)

The actuator is supplied prearranged for 0-10V control signal, direct action and fully extended return position (DOWN); to modify this setting, follow these instructions:

- Remove the cover and the connector (look at the following picture).
- Change the DIP switches as indicated in the following scheme.
- The new settings will be active on the next power off/on cycle.

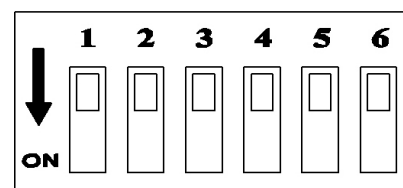

DIP	ON	OFF
1	Reverse action	Direct action
2	2-10/6-10 V	0-10/0-5 V
3	Range SEQ	Range NORM
4	Not applicable	Auto calibrated stroke
5	4-20 mA	DC Voltage range
6	Calibration	Running

The actuator can be coupled with iSMA CONTROLLI valves without spring using auto calibration stroke; or to valves with spring return using fixed stroke. Actuators with fixed stroke (DIP 4 ON) have only reverse action.

Automatic stroke calibration (valid only for DIP n. 4 in OFF)

This function helps to calibrate the maximum valve time stroke, so that the actuator can place the valve correctly following the control signal. If the actuator is powered on, this action can be repeated any time DIP 6 goes from OFF to ON and DIP 4 is OFF. During normal operation, it is possible to choose the position of DIP 6: at each start up the stroke calibration will be carried out if DIP 6 is ON; it will be maintained the previous stroke if DIP 6 is OFF.

Direct/Reverse action

Through DIP 1 is possible to set direct or reverse action. In direct action without control signal the actuator is fully retracted with feedback set to 2V. With reverse action the actuator is fully extended and the feedback without control signal is 2 V in this position.

Setting Control Signal Fields

Through DIP 2, 3 and 5 it is possible to set 5 different input ranges. If DIP 5 is ON, the input range is set at 4-20mA and DIP 2 and 3 have no meaning. If DIP 5 is OFF, the possible ranges are: 0-10/2-10 if DIP 3 is OFF and 0-5/6-10 if DIP 3 is ON.

Initial Positioning

It is executed every time the actuator is powered and before to have performed the learning of the race. This operation allows the servocontrol to start from a certain position for then follow the command signal. This position depends on the selection made on DIP 1 (DIP 4 OFF).

If DIP 4 is ON, the initial position is with MVC fully extended (actuators with fixed stroke valves have only the inverse action).

Unexpected stall condition

If an unexpected stop during the stroke occurs, this function has the aim to make it disappear. The actuator will be driven in the opposite direction and then it will try again to reach the position.

If it was not unlocked after the first 3 attempts, after a 1 minute pause, 3 more attempts are made.

Feedback output signal (2-10V)

The actuator is equipped with a proper output to transmit the feedback signal relating to the supposed actuator position. This signal can vary from 2 to 10V. During the "automatic stroke calibration" and "Initial positioning" function it is set at 2V. During the emergency positioning function the feedback signal is set to 1V.

Manual override

To activate the manual override, remove the power supply, remove the transparent cover and insert a 3 mm hexagonal key into the front hole and turn the key until the desired position is reached.

LEDs OPERATION

LED	CALIBRATION PHASE	INITIAL POSITIO-NING	UP POSITIONING	END STROKE UP	DOWN POSITIO-NING	END STROLE DOWN	ACTUATOR STOP	UNEXPECTED STALL	LOW SUPPLYVOL-TAGE	ACTUATOR OFF OR UNDER RESET (SUP-PLY VOLTAGE LOW)	MAX STROKE LIMIT PHASE
RED	ALTERNA-TING 5Hz	ALTERNA-TING 1Hz	OFF	OFF	BLIN-KING 1Hz	ON	OFF	SIMULTANE- OUS 5Hz	OFF	OFF	ON
GREEN			BLIN-KING 1Hz	ON	OFF	OFF	OFF		OFF	OFF	ON
YELLOW	ON	ON	ON	ON	ON	ON	ON	ON	BLIN-KING 1Hz	OFF	ON

DL1 DL2 DL3



MANUAL OVERRIDE HOLE ACCESSIBLE ONLY
REMOVING THE TRANSPARENT COVER

DIMENSIONS [mm]

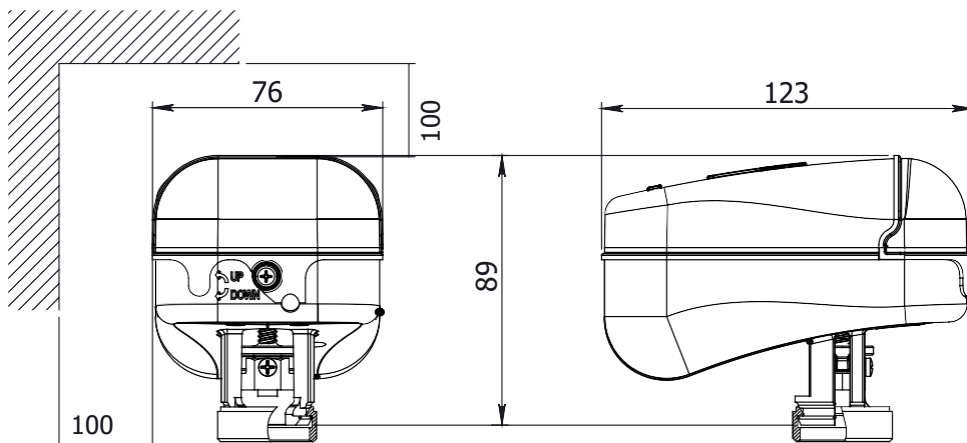

QUICKLINK SOLUTIONS S.r.l. | info@qlsol.com

North West Office: Via G. Matteotti 193-203, 21044 Cavaria con Premezzo (VA), Italy

North East Office: Via F. Petrarca, 34, 35020 Albignasego (PD), Italy