

## Electrothermal actuator for zone valves and terminal units

MODEL	POWER SUPPLY	CONTROL
MVX22R	110-230 V AC	ON/OFF
MVX42R	24 V AC/DC	
MVX52	24 V AC	Proportional 0-10 V



### APPLICATION AND USE

MVX electrothermal actuators can be used with Micra® and Micra® Kvs 4-6 valves (DBL199en and DBL293en).

### OPERATION

The actuator-valve assembly is easily made thanks to its threaded ring nut, which allows a comfortable cable positioning. All models are provided with a yellow stroke indicator (see below).

The actuators are available in the ON-OFF (230 V and 24 V) and in modulating (24 V) with 0-10 V DC signal versions.

### OPTIONS

**PS107** actuator with M28x1,5 modified ring nut. For ordering add suffix PS107 to standard codes.

### TECHNICAL CHARACTERISTICS

CHARACTERISTIC	MVX22R	MVX42R	MVX52
Power supply	110 - 230 V AC / 24 V AC/DC		24 Vac
Frequency	50/60 Hz		
Power cable	2 m bipolar (0,35 mm <sup>2</sup> )		2 m triple-pole (0,35 mm <sup>2</sup> )
Protection degree	IP44 (vertical mounting)		
Operation temperature	2±50 °C		
Storage temperature	-10±60 °C		
Force	140 N		
Stroke	4 mm		2,5 mm
Material	Technopolymer fire-resistant case (class V0)		

The performances stated in this sheet can be modified without any prior notice.

CONSUMPTION	MVX22R 230 V	MVX22R 110V	MVX42R* 24 V	MVX52 24 V
Starting	50 VA	12 VA	4 VA (4 W)	5 VA
Operation	1,8 VA	1,8 VA	1,8 VA (1,8 W)	1,8 VA

\* the values in brackets refer to the DC power supply.

### Starting Time

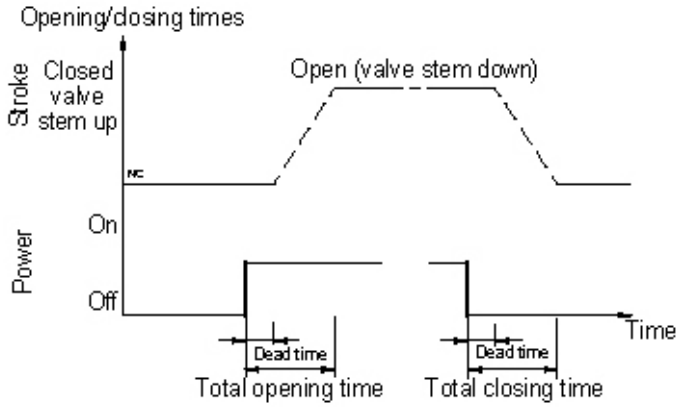

ACTUATOR TIMING DETAILS (APPROX.) IN SECONDS							
Actuator	Voltage	Valve opening		Valve closing (after 5' power on)		Valve closing (after 30' power on)	
		Dead zone	Total time	Dead zone	Total time	Dead zone	Total time
MVX22R	230 V	80	230	180	390	150	400
	110 V	100	380	80	330	80	330
MVX42R MVX52	24 V	150	400	180	390	150	400

### ELECTRIC CONNECTIONS (MVX52)

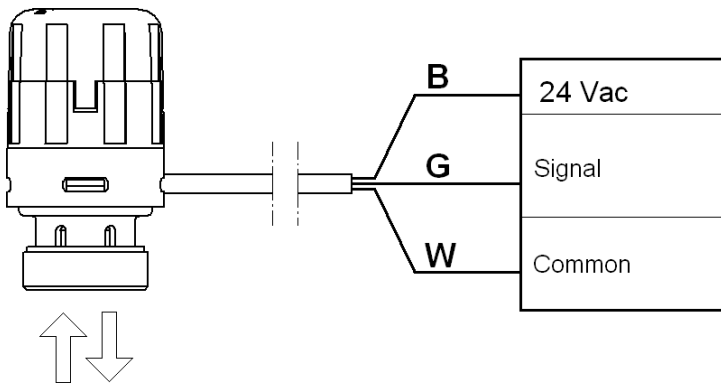

B = brown (24 V AC - 50/60 Hz)  
 G = green (control signal 0-10 V DC) W = white (common)

### SAFETY PERSCRIPTIONS

#### 230 V products

- Install on the power supply line a screening device to avoid short circuits (fuse or magneto-thermic) according to the reference standards.
- In case of actuator removing from skilled staff, be sure that the power supply is disconnected.
- Products are maintenance free.

