

# LIBRA

## Pressure Independent Control Valves



### APPLICATION AND USE

A Pressure Independent Control Valve (PICV) is a valve that can be fitted in heating and chilled water systems to provide:

- flow control - enabling modulating control of heating/cooling outputs;
- flow adjustment - enabling flow rates to be set at their specified design values;
- differential pressure control - ensuring a constant differential pressure across control valves regardless of changes in pump speed or valve closures elsewhere in the system.

This means that each PICV replaces up to three separate valves that would otherwise be required (i.e., regulating valve, two port control valve, plus a differential pressure control valve).

Pressure-independent control valves are exactly what the name suggests. They maintain a constant pre-set differential pressure across a control valve such that control action of the valve is not affected by inlet-pressure instability.

PICVs are suitable for a wide range of hydronic applications in the building services industry. Fan-coil units, air handling units and chilled beams are probably the most familiar applications of pressure independent control valves with the move from 3-ports to 2-ports valves driven primarily by the need to reduce excessive energy consumption of pumps and thermal losses through pipework.

In the selection of 2-ports valves for use in variable-flow systems, particular attention is given to some of the issues that can arise in systems where pump speed is designed to change in response to thermal demand.

Fluctuations of flow initiated by the positioning of the 2-ports valves in response to varying occupancy levels and heat losses cause pressure changes in the system, resulting in instability of flow through all the valves.

The system is effectively unbalanced, resulting in the valves 'hunting' as they constantly try to maintain control.

An unstable system has a direct impact on energy consumption, occupancy comfort, noise and maintenance costs.

To ensure accurate temperature control in the occupied spaces of buildings where the system pressure is maintained by a variable- or constant-speed pump installation, it is crucial that pressure fluctuations do not affect the flow through terminal units.

The solution is to install 2-ports control valves that can maintain close control of flow independently of the system pressure variation caused by changes in pump speed or the operation of other valves.

### TECHNICAL CHARACTERISTICS

DESCRIPTION	PICV
Valve body	Brass CW 617 (DN15÷32) Cast iron EN-GJS-400-15 (DN40÷50)
Plug	AISI 304
Flow setting knob	IXEF GF40
Spring	AISI 302

The performances stated in this sheet can be modified without any prior notice.

DESCRIPTION	PICV
Diaphragm	EPDM 70 Sh
O-rings	EPDM 70
Pressure class	PN16
Min. differential pressure	20-35 kPa* depending on caliber position (see table and charts below)
Max. differential pressure	600 kPa (DN15÷32), 800 kPa (DN40÷50)
Fluid temperature	-10-120°C
Leakage	Tight close-off
Pressure plugs connections	Available on VLX.P models (Type M UNI-EN-ISO 228 1/8")

\* This is the minimum requested differential pressure across the valve in order to minimize the flow tolerance. The valve can work with a lower differential pressure with a lower maximum flow.

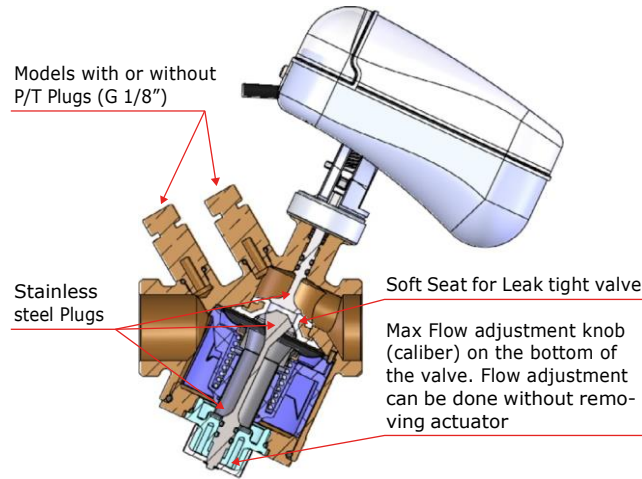

MODEL	P/T PLUGS	DN	VALVE CONNECTION	QMIN [l/h]	QMAX [l/h]	DPMAX [kPa]	STROKE [mm]
VLX1	NO	15	1/2" M	100	375	600	4
VLX1P	YES						
VLX2	NO		3/4" M	145	800		
VLX2P	YES						
VLX3	NO	20	1" M	200	1000		
VLX3P	YES						
VLX4	NO	25	1 1/4" M	200	2000		
VLX4P	YES						
VLX5	NO	32	1 1/2" M	400	4000		
VLX5P	YES						
VLX6P	YES	40	1 1/2" F	1100	10000	800	15
VLX8P	YES						

## APPLICATIONS EXAMPLE

### Variable Flow Systems

A motorised control valve that automatically limits the maximum flow rate, maximizing the coil efficiency, independently from the available pressures and, at the same time, it allows the room temperature control by means of a flow controller driven by a remotely controlled actuator.

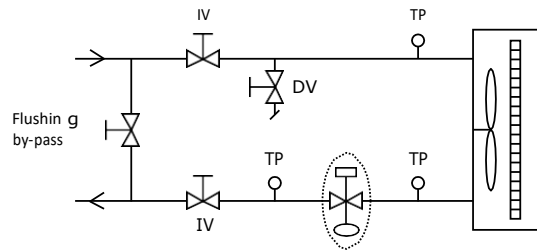

PICV is used as a constant flow limiter and control valve.

### Constant Flow Systems

The valve without the actuator is used to adjust fan-coil flow, it ensures the required flow rate to the equipment and it ensure the hydraulic balancing of the system. The coil always works in the best conditions possible with any differential pressure.

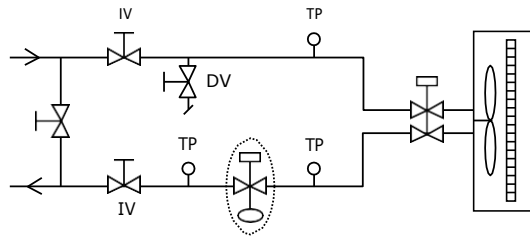

PICV is used as a constant flow limiter.

### HOW DOES A LIBRA PICV WORK

The design of a pressure independent control valve combines three critical functions.

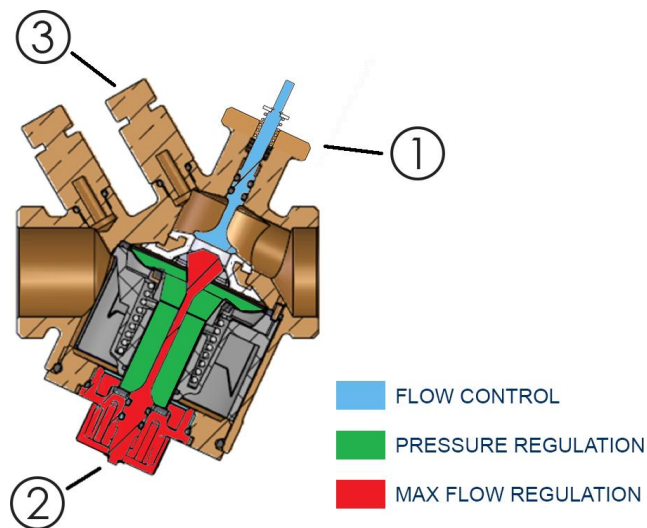
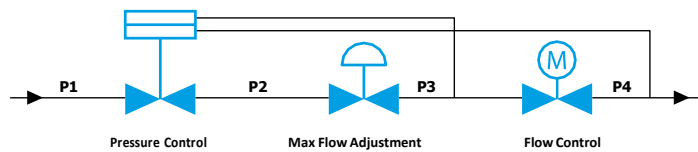

### Differential Pressure Control

A spring-operated diaphragm valve at the inlet of the valve automatically adjusts the differential pressure across the inlet and outlet ports to maintain a constant. One side of the diaphragm is in contact with water from the inlet to the valve at a pressure P1, where- as the other side is in contact with water from the outlet to the valve at a pressure P4. This means that if there is any change in the differential pressure P1 to P4, the position of the differential pressure regulator will also change. The result will be that the differential pressure P3 to P4 (i.e. from downstream of the differential pressure regulator to the valve outlet) will remain constant at all times regardless of changes in the overall differential pressure P1 to P4.

This ensures (providing the range of inlet pressure variations are within the valves specification) that the differential pressure across the flow control valve will remain constant within its specified tolerances.

### Max Flow Adjustment

A manually adjustable plug allows the flow through the valve to be set to the design flow rate. The plug is combined with the function of the pressure-regulating valve, ensures that the design flow rate is maintained irrespective of varying inlet pressures.

Once the flow regulator has been pre-set to the desired flowrate and the differential pressure is within the specified range, a constant pre-set flow will be maintained. A valve that has the combination of pressure and flow regulation is an effective device for maintaining a constant flow rate through downstream pipework. These are essentially pressure-independent constant-flow valves without the valve control function and actuator. The addition of actuator and valve provides the control element to the valve.

### Flow Control

The control function is a remotely actuated plug located downstream the pressure and flow regulators. Opening and closing the control plug varies the flow through the valve, providing the control function that will respond to an input signal from a discrete terminal controller or a BMS. The maximum flow is set by the flow regulator, and the required differential pressure is maintained by the pressure regulator — enabling the control valve to give accurate control independent of fluctuations of inlet or line pressure.

Pressure tapings built into the valve allow the overall pressure differential P1 to P4 to be measured to ensure that the valve is operating within the manufacturer's stated pressure differential range.

### LIBRA ADVANTAGES

Using pressure independent control valves any fluctuation in the pressure P1 due to changes in pump speed or the closure of other valves in the system will dynamically be compensated for by the action of the differential pressure controller. The result is that the flow rate pumped to the coils is constant and independent from the system pressure fluctuations. When the valve is equipped with an actuator then the flow rate will only depend from the BMS control signal.

The ability of the LIBRA to maintain a constant flow depending from the BMS control signal only has three important implications:

- the coil will receive the proper flow according to the design specification and therefore pumping energy is not wasted due to overflow phenomena occurring when some valves in the systems are closing and therefore the differential pressure across the other valves is growing;
- overflow phenomena are also leading to a reduction of the DeltaT between supply and return with a following reduction of the generation efficiency of the boilers and/or chillers;
- the control valve characteristic is independent from the pressure drops in the branch/circuit for which it is controlling flow and therefore the valve will have a 100% authority being able to effectively control at part load.

Furthermore LIBRAs bring other benefits like:

- LIBRA combines 3 valves in 1 with a relevant installation and commissioning cost saving;
- LIBRA commissioning is extremely easy due to the possibility to set the design flow on each valve by means of the manual knob on the bottom of the valve;
- LIBRA allows a dynamic hydraulic balancing and therefore commissioning does not have to be repeated in case of changes in the system;
- max. flow regulation does not reduce the control stroke: 100% stroke always;
- no cartridge design for an easier valve selection;
- max. flow adjustment knob on the bottom of the valve easily accessible without removing the actuator.

### LIBRA FLOW CHARACTERISTICS

LIBRA can be characterized by two different flow curves:

- flow vs valve opening;
- flow vs differential pressure.

The first curve (figure 1) shows how the flow changes according to the valve opening from fully closed to fully open condition.

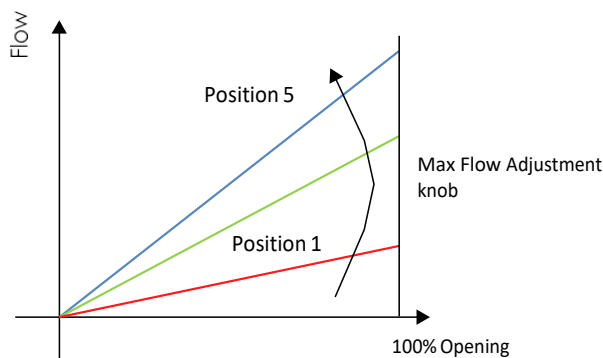

Figure 1

The second curve (figure 2) shows that LIBRA has a minimum and maximum pressure differential value below or above which the valve will not compensate differential pressure changes. If the pressure differential is less than the minimum value, the spring inside the pressure regulator remains fully extended, whereas at pressure differentials greater than the maximum value, the spring is fully compressed.

Under both of these conditions the pressure control element in the valve acts as a fixed resistance; the valve can only control flow when the spring is under some degree of partial compression. The “operating range” of the valve is the range of differential pressures for which control is possible.

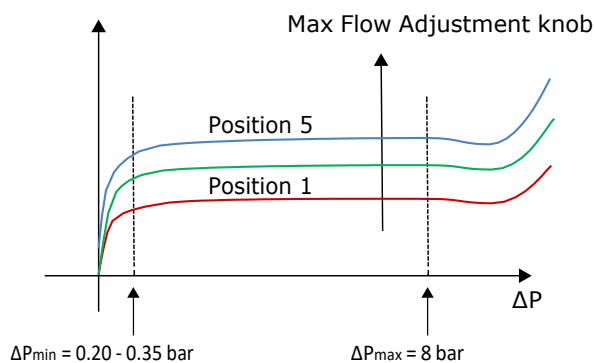
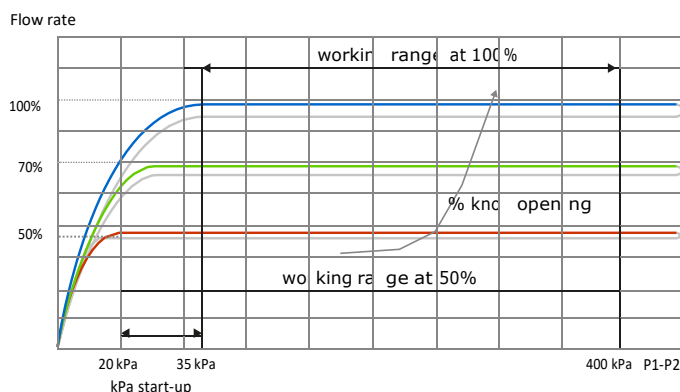

Figure 2

Within its operating range, the flow through the valve stabilises, although as can be seen in the above, even in this range the flow rate is not constant. If the pressure across the valve is allowed to vary between its minimum and maximum operating pressures, its flow may vary by up to approximately  $\pm 10\%$  from its set point value.

Due to the fact that LIBRA is equipped with a max. flow regulator, the two above flow characteristics depends on the current position of the Max flow adjustment knob.

It has to be noticed that the start-up differential pressure depend on the max flow setting: the lower is the max flow the lower is the start up differential pressure.



In the table below the max flow and the start up differential pressure are reported for each adjustment knob position.

CALIBER	VLX1/VLX1P		VLX2/VLX2P		VLX3/VLX3P		VLX4/VLX4P		VLX5/VLX5P	
	$Q_{MAX}$ [l/h]	MIN DP [kPa]	$Q_{MAX}$ [l/h]	MIN DP [kPa]	$Q_{MAX}$ [l/h]	MIN DP [kPa]	$Q_{MAX}$ [l/h]	MIN DP [kPa]	$Q_{MAX}$ [l/h]	MIN DP [kPa]
5	375	35	800	35	1000	35	2000	35	4000	35
4	300	30	575	30	750	30	1400	30	3000	35
3	240	25	360	25	480	25	840	25	1600	30
2	150	25	215	25	300	22	480	20	800	25
1	100	20	145	25	200	20	200	20	400	25

CALIBER	VLX6P		VLX8P	
	Q <sub>MAX</sub> [l/h]	MIN DP [kPa]	Q <sub>MAX</sub> [l/h]	MIN DP [kPa]
5	10000	35	12500	35
4	7000	35	9000	35
3	4800	30	6500	30
2	2750	30	4800	30
1	1100	30	2200	30

## HYSTERESIS

The accuracy with which the flow rate setting is maintained also depends on whether the pressure differential across the valve is rising or falling. It can be seen from the following figure that there are distinct rising and falling pressure curves.

The difference between the two curves is often referred to as the valve's "hysteresis". The hysteresis effect is caused by the sealing elements in the pressure regulating part of the valve. Due to hysteresis, two repeatable flow readings can be obtained depending on whether the pressure differential across the valve has risen or fallen to the value when the measurement is taken. Since the valves are factory tested on their rising pressure curves, the flow setting device indicates flows that correspond to a rising rather than decreasing pressure differential. For the reasons explained, the valve's proportional band and hysteresis may cause flow values to vary from their set values.

These effects can be minimised by ensuring that systems are:

- designed such that when a PICV opens to increase the flow rate to a terminal unit, its pressure differential simultaneously increases rather than decreases.
- commissioned such that when a PICV is set to its required flow rate, the pressure differential across the valve is as close as possible to its final operating value.

Both of these objectives can be easily achieved by ensuring that during commissioning and subsequent system operation, pump pressure always reduces as PICVs close. The best way to achieve this is to set the pump speed controller such that a constant pressure differential is maintained at a differential pressure sensor located towards the index PICV i.e. the PICV located furthest from the pump.

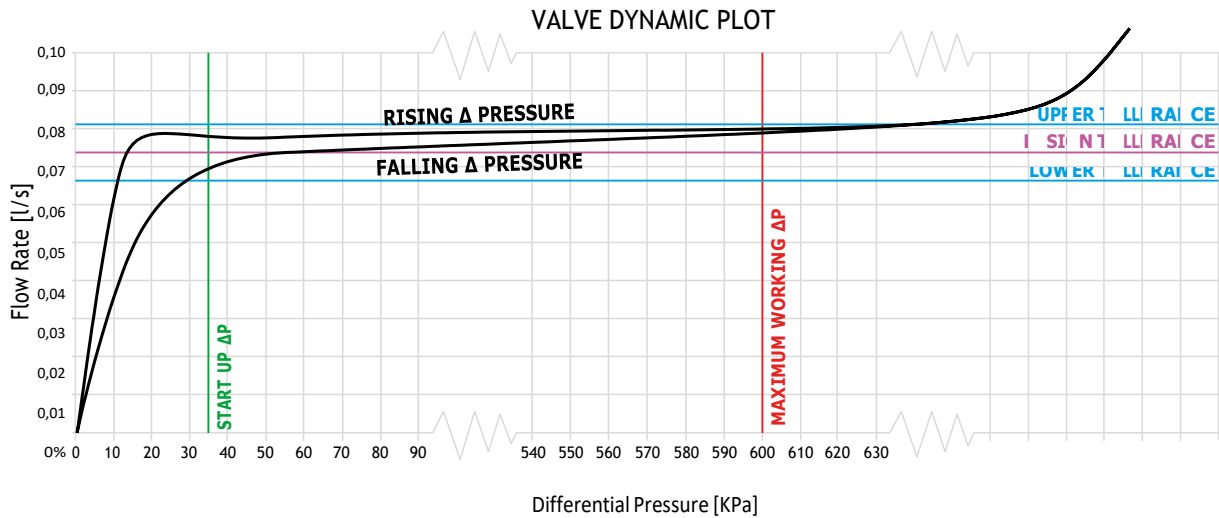

A single sensor located two thirds of the way along the farthest branch is satisfactory in systems with a uniform load pattern; alternatively, multiple sensors across the most remote PICV controlled terminal branches can be used in systems with an unpredictable and varying load pattern. Controlling pump speed such that pump pressure is maintained constant should be avoided wherever possible. This solution inevitably results in large increases in pressure differential across PICVs as they close, resulting in the largest possible variations from set flow rate values but in any case much better than standard two ports.

## VALVE AUTHORITY

Valve authority concept is used to express in a simple way a control valves's share of the pressure drop in relation to the total pressure drop of the controlled circuit. It is mathematically defined as follows:

$$\beta = \frac{\Delta P_{\text{valve}}}{\Delta P_{\text{valve}} + \Delta P_{\text{coil}} + \Delta P_{\text{other}}}$$

**ΔP<sub>valve</sub>** is the pressure drop of the valve at the design flow and 100% opening

**ΔP<sub>coil</sub>** is the pressure drop of the coil on which the valve is changing the flow

**ΔP<sub>other</sub>** is the pressure drop of the other components of the controlled circuit

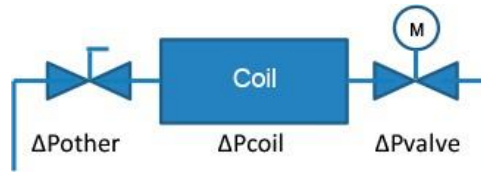

In other words the valve authority express the capability of the valve to control the flow according to the flow characteristics when installed in a system; the lower is the authority the higher is the distortion of the valve characteristics and therefore the lower is the capability of the valve to control at part loads.

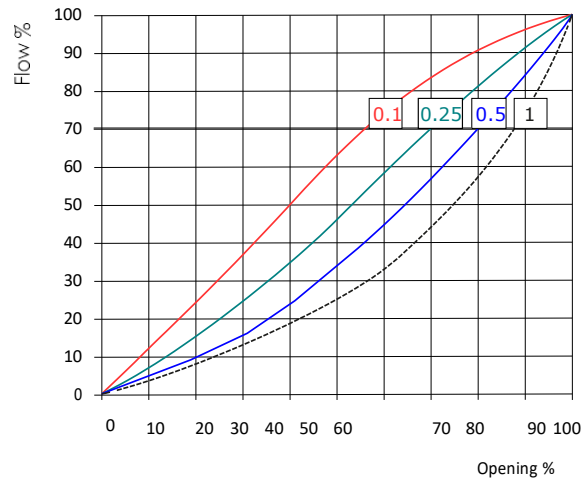

In order to have a proper control valve authority should not be less than 50% otherwise the valve will result oversized inducing unstable behaviour.

Talking about LIBRA pressure independent control valve since the pressure drop across the control valve section is constant at allflows then the control valve can control equally well at both part load and full loads. Hence the LIBRA PICV has full control over the 100% of the load, which is what we expect from a control valve with 100% authority.

## WATER QUALITY

PICVs can be sensitive to high levels of particulate dirt which causes fouling of the low pressure areas within the valve. Strainers are not effective enough at removing this kind of dirt from the media as the mesh size usually installed is too large to trap such tiny particles. This kind of fouling can only be prevented by ensuring a water quality of a high standard by on-going water treatment and filtration.

Water quality in hydronic systems can be divided into two categories:

- physical water quality;
- chemical water quality.

Physical water quality relates to issues such as capturing and eliminating dirt from the system. Filters, with properly selected mesh size, and dirt separator have to be installed on the main branch of the pipeworks to remove physical particles in the water.

Chemical water quality deals with modifying or eliminating various chemical substances in water so that it is well suited for use in a hydronic system. Systems for adjustment of the pH value of the water, control the water hardness and the electrical conductivity have to be installed in order to minimize corrosion and fouling phenomena that will contribute to dirt generation into the system.

According to VDI 2035, we recommend the following water quality specification:

- electric conductivity: < 100  $\mu$ S;
- pH-Value: 8,2 – 10 pH (8,2 – 8,5 Aluminium);
- total hardness: 5-15 $^{\circ}$ f.

## LIBRA RANGE

iSMA CONTROLLI is able to supply a complete range of PICV valve from DN15 up to DN50 and with flows from 375 l/h up to 12500 l/h

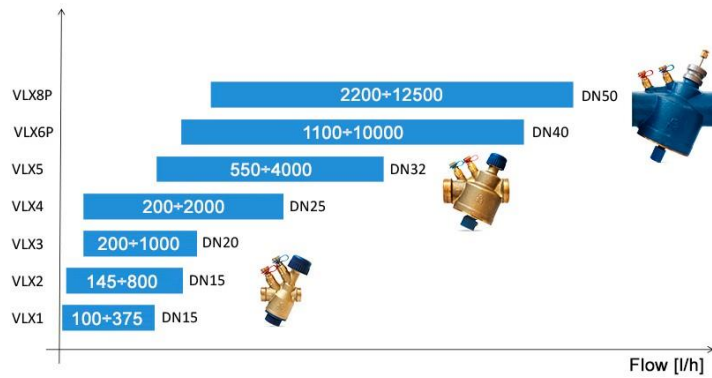

## AVAILABLE ACTUATORS

Libra valves can be motorized with different actuators depending on the requested control type as well as the size of the valve itself.

### VLX1(P), VLX2(P), VLX3(P), VLX4(P)

#### On-off

MVR24C2 (24 V AC\DC), MVR24MC2 (24 V AC\DC with end point switch)  
 MVR230C2 (230 V AC), MVR24MC2 (24 V AC with end point switch) MCA24L (24 V AC\DC), MCA24LM (24 V AC\DC with end point switch) MCA24L (230 V AC), MCA24LM (230 V AC with end point switch)

#### Proportional – 3-point Floating

MVT403S (24 V AC), MVT203S (230 V AC)

#### Proportional – 0-10 V DC

MVX52B (Thermic, 24 V AC)  
 MVT503SB (Mechanical, 24 V AC)  
 MVC503R (Mechanical, 24 V AC\DC, emergency return)  
 MVC503R-MB (Mechanical, 24 V AC\DC, emergency return, Modbus)

### VLX5(P)

#### Proportional – 3-point Floating

MVT403S (24 V AC), MVT203S (230 V AC)

#### Proportional – 0-10 V DC

MVT503SB (mechanical, 24 V AC)  
 MVC503R (mechanical, 24 V AC\DC, emergency return)

### VLX6P, VLX8P

#### Proportional – 3 point Floating & Modulating (Field Selectable)

MVE504S (mechanical, 24 V AC\DC, IP54)  
 MVE504S-65 (mechanical, 24 V AC\DC, IP65)  
 MVE504SR (mechanical, 24 V AC\DC, IP54, emergency return) MVE504SR-65 (mechanical, 24 V AC\DC, IP65, emergency return) MVE204S (mechanical, 230 V AC, IP54)  
 MVE204S-65 (mechanical, 230 V AC, IP65)  
 MVE204SR (mechanical, 230 V AC, IP54, emergency return) MVE204SR-65 (mechanical, 230 V AC, IP65, emergency return)



MODEL	ELECTROTHERMAL ACTUATORS			MOTORIC ACTUATORS			MAX CLOSE OFF PRESSURE [KPA]
	ON/OFF		0-10 V	3 P	0-10 V	3P/0-10 V	
	MCA230L MCA24L	MVR24C2 MVR230C2	MX52B	MVT203S MVT403S	MVT503SB MVC503R MVC503R-MB	MVE504S(-65) MVE504SR(-65) MVE204S(-65) MVE204SR(-65)	
VLX1	X	X	X	X	X	-	600
VLX1P	X	X	X	X	X	-	
VLX2	X	X	X	X	X	-	
VLX2P	X	X	X	X	X	-	
VLX3	X	X	X	X	X	-	
VLX3P	X	X	X	X	X	-	
VLX4	X	X	X	X	X	-	
VLX4P	X	X	X	X	X	-	
VLX5	-	-	-	X	X	-	800
VLX5P	-	-	-	X	X	-	
VLX6P	-	-	-	-	-	X	
VLX8P	-	-	-	-	-	X	

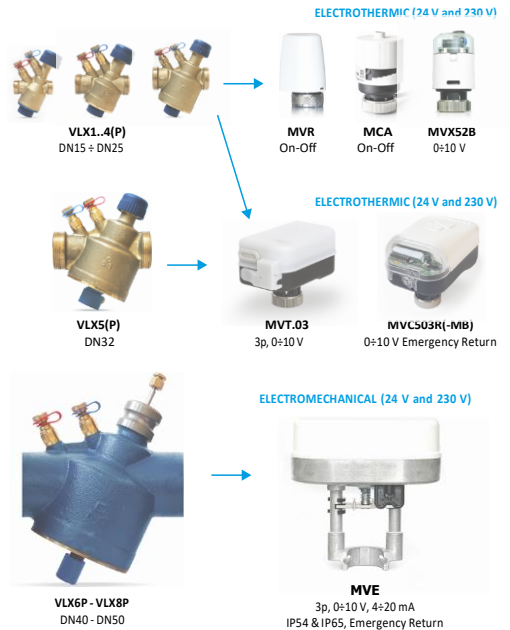

Furthermore, the following key features will be available for the LIBRA range using the Modbus version of MVC and MVE actuator:

- Modbus setting of the valve stroke for a remote commissioning;
- Modbus setting of the flow characteristic equipcentage versus linear.

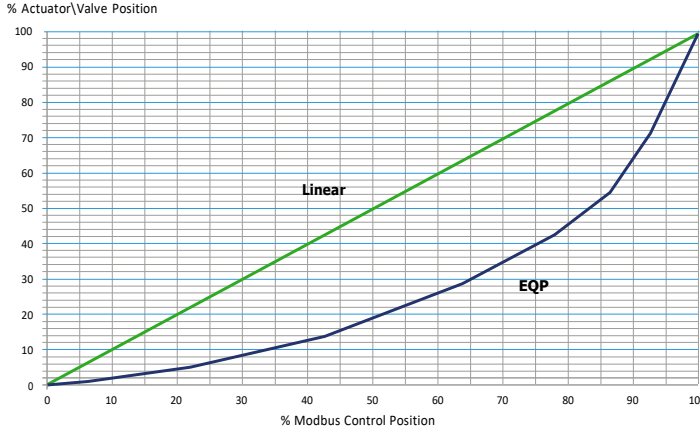

Different actuators have different technical features like Protection Degree (IP), Timing, End Point switch etc, but all can provide the same maximum close off pressure. Please see actuator technical datasheet on [www.ismacontrolli.com](http://www.ismacontrolli.com) for details.

PICVs can also be supplied as a complete hook-up kit for FCUs. For an easy and error free installation. Hook-up kit includes strainer and by-pass for a safe and long-term operation of PICV.



For an easy and fast selection of the Libra PICV, a MS Excel software tool is available.

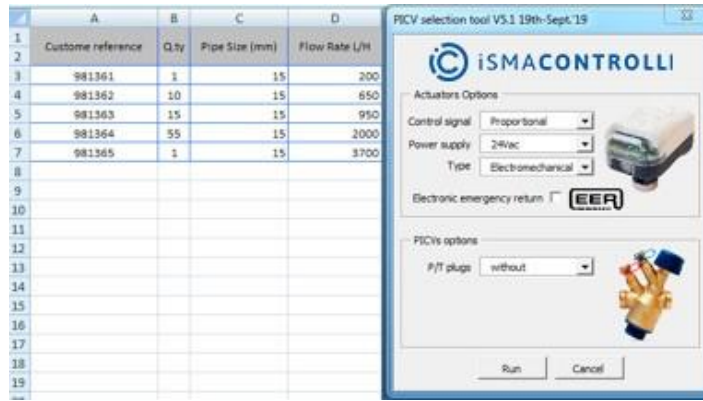

The user has to fill in a table with the quantities and the design flow rate of the requested PICV, select power supply, control type of the requested actuator and the software will automatically produce a bill of material.

Item Code	Item type	Description	Q.ty
VLX1	PICV	1/2" connection, max flow 375 l/h	1
VLX2	PICV	3/4" connection, max flow 800 l/h	10
VLX3	PICV	1" connection, max flow 1000 l/h	15
VLX4	PICV	1 1/4" connection, max flow 2000 l/h	55
MVC503R	Actuator	Electromechanical proportional 24Vac 300N	82

Other available accessories are:



INSTALLATION & COMMISSIONING

LIBRA can be mounted in either the flow or return pipework serving terminal units. Libra can be mounted with any orientation but not up-side-down. Consideration should be given to the flushing regime when deciding on the position of the valve in order to minimize the risk that large contaminants circulating in the system can damage the valve.

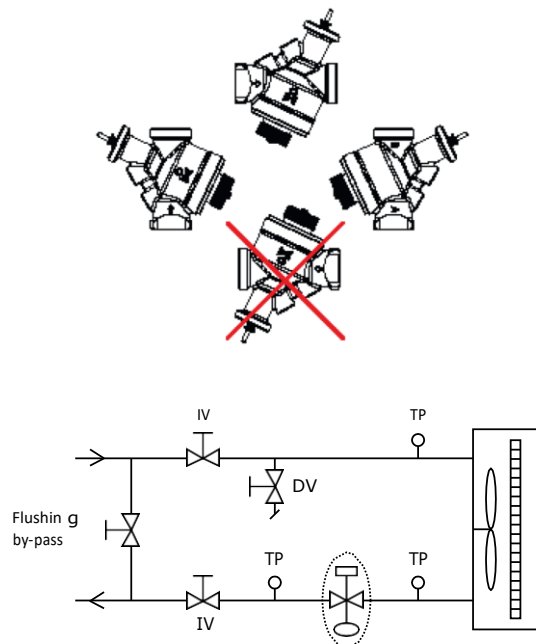

Filters and dirt separator shall always be installed on the main branch pipework feeding terminals served by PICVs.

Water or water/glycol mixture quality shall be in accordance to VDI 2035 guidelines and with temperature from -10 to 120 °C.

The use of hook up kit integrating a flushing by-pass as well as a strainer is recommended for a safe and long term use of the LIBRA pressure independent control valves.

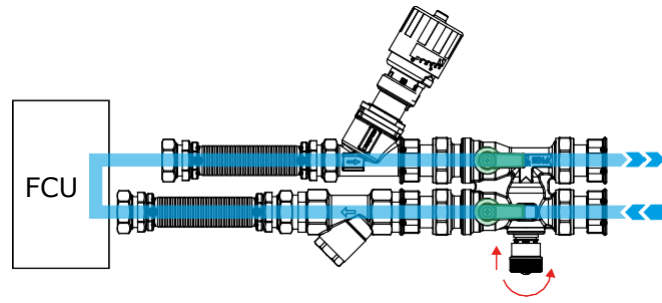

NORMAL FUNCTIONING

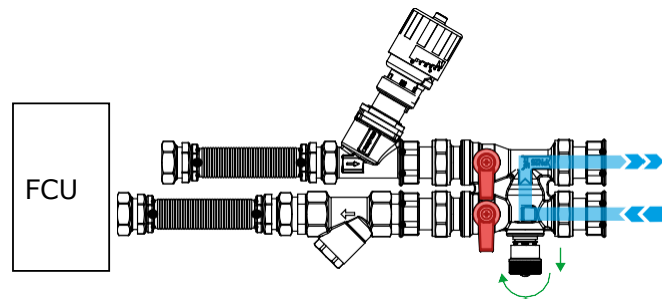

BYPASS FUNCTIONING

Each LIBRA valve can be set independently and in any order provided there is sufficient pressure available to enable its integral spring-operated diaphragm to operate. Branches close to the pump are most likely to have sufficient pressure at start up and are therefore an obvious place to start.

The commissioning procedure is as follows:

1. For the selected VLX valve, ensure that the 2 port valve is fully open. Measure the pressure differential across its pressure tap-pings and confirm that the value obtained is greater than the minimum value indicated in the product brochure. If this is not the case investigate the causes and, if necessary, report to the designer.
2. Position the max flow adjustment knob to the specified design flow rate (for VLX5, VLX5P, VLX6P and VLX8P model use the locking screw to fix the position) and record the setting.
3. Repeat the above process for all of the LIBRA valves on the branch.
4. Measure the flow rate indicated at the flow measurement device on the branch. Confirm that the value recorded is equal to the sum of the flows set at downstream LIBRA valves. If this is not the case investigate the causes and, if necessary, report to the designer.
5. Repeat this procedure until all LIBRA valves in the system have been set and their summated flows checked against upstream flow measurement devices.
6. Measure the differential pressure across the LIBRA on the system index terminal (usually the most remote terminal from the pump). Adjust the pump speed until the pressure differential across valve is equal to the minimum value indicated in the product brochure. **Please consider that if the valve on the system index terminal unit (the farthest valve from the pump) will experience a differential pressure lower than the minimum DeltaP specified at the current caliber position (i.e. 25kPa) it means the flow tolerance will be higher on that valve; instead all the others valves in the system will most probably experience a valve differential pressure higher than 35 kPa and therefore the energy saving benefit will not be affected significantly.**
7. Determine the pressure differential at the sensor location. Usually the sensor is placed at the distance from the pump equal to 2/3 of the distance of the farthest terminal from the pump itself. Set the pump speed to control such that the value indicated at the sensor is maintained constant under all conditions.
8. Measure and record the total flow rate, pressure differential and energy consumption at the pump.
9. Run all two port valves to their closed positions. Measure and record the total flow rate, pressure differential and energy consumption at the pump. Calculate and report the overall energy saving achieved i.e. between full load and minimum load operation.

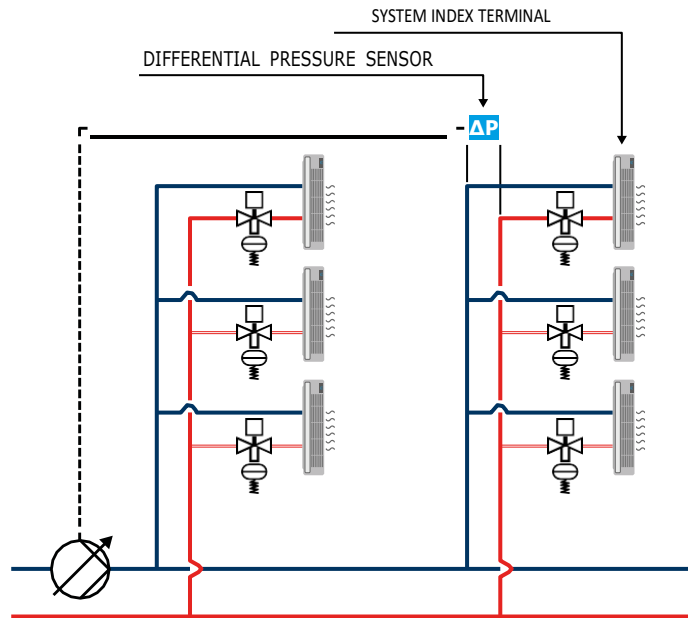

PICV CALIBER

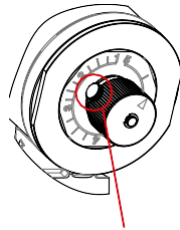

Locking Screw (VLX5/VLX5P ONLY)



DMP700

FLOW CHARTS

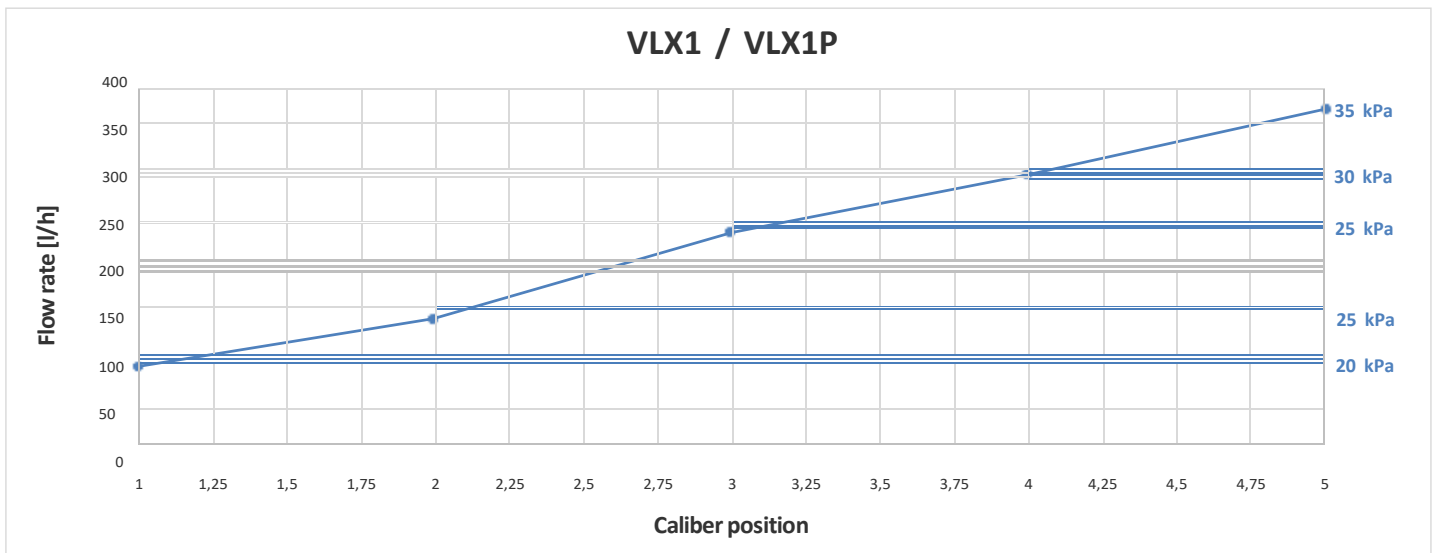

### VLX2 / VLX2P

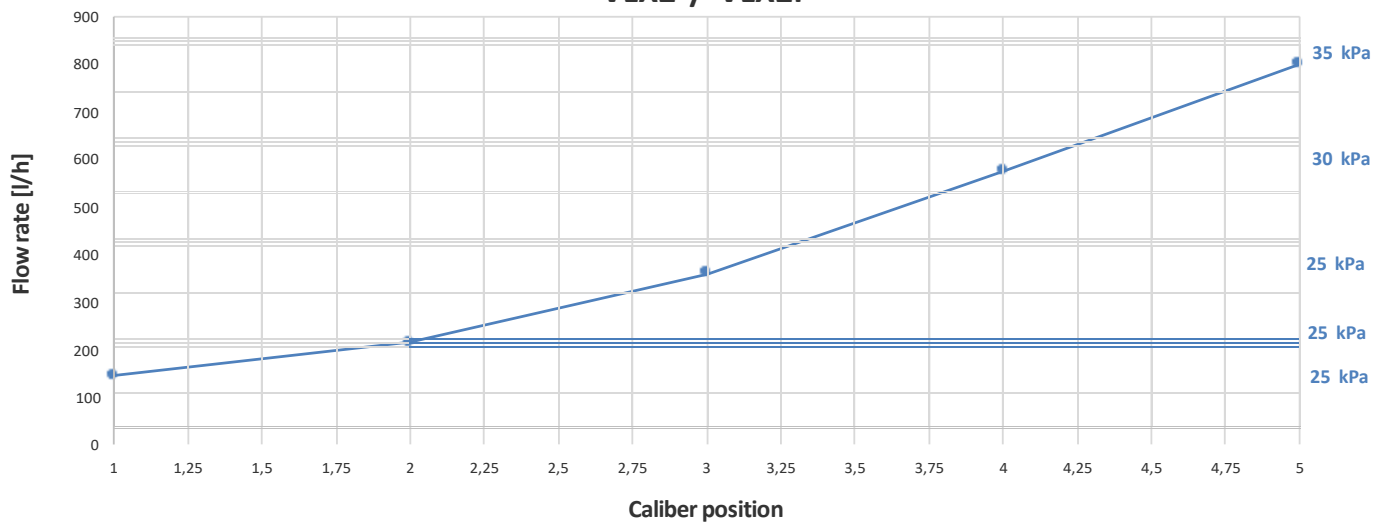

### VLX3 / VLX3P

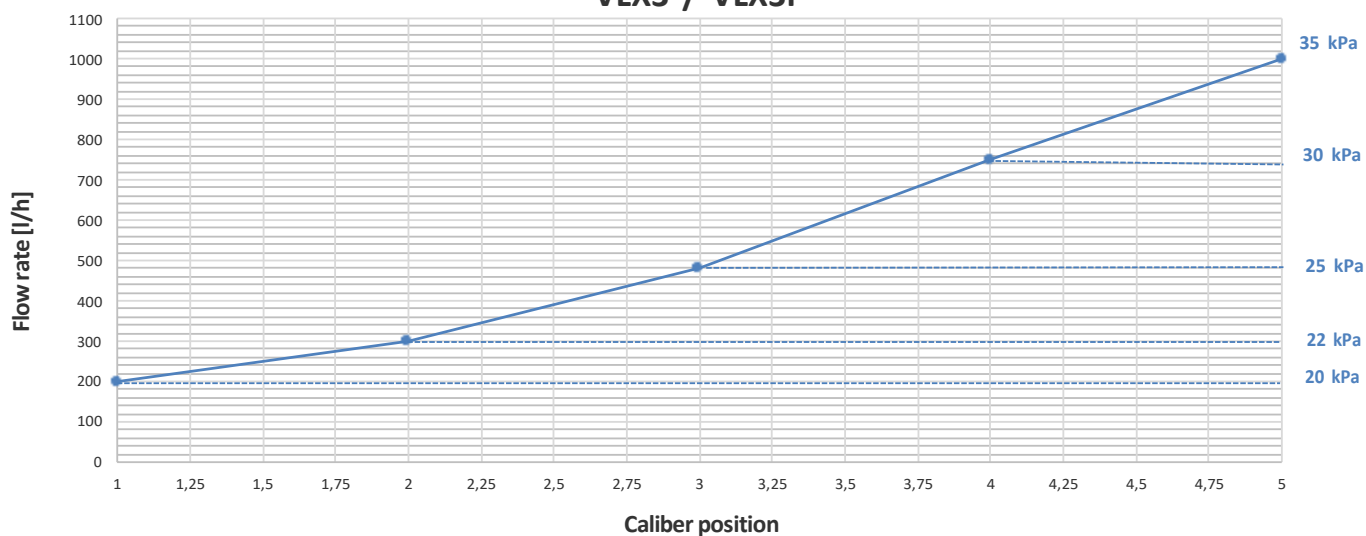

### VLX4 / VLX4P

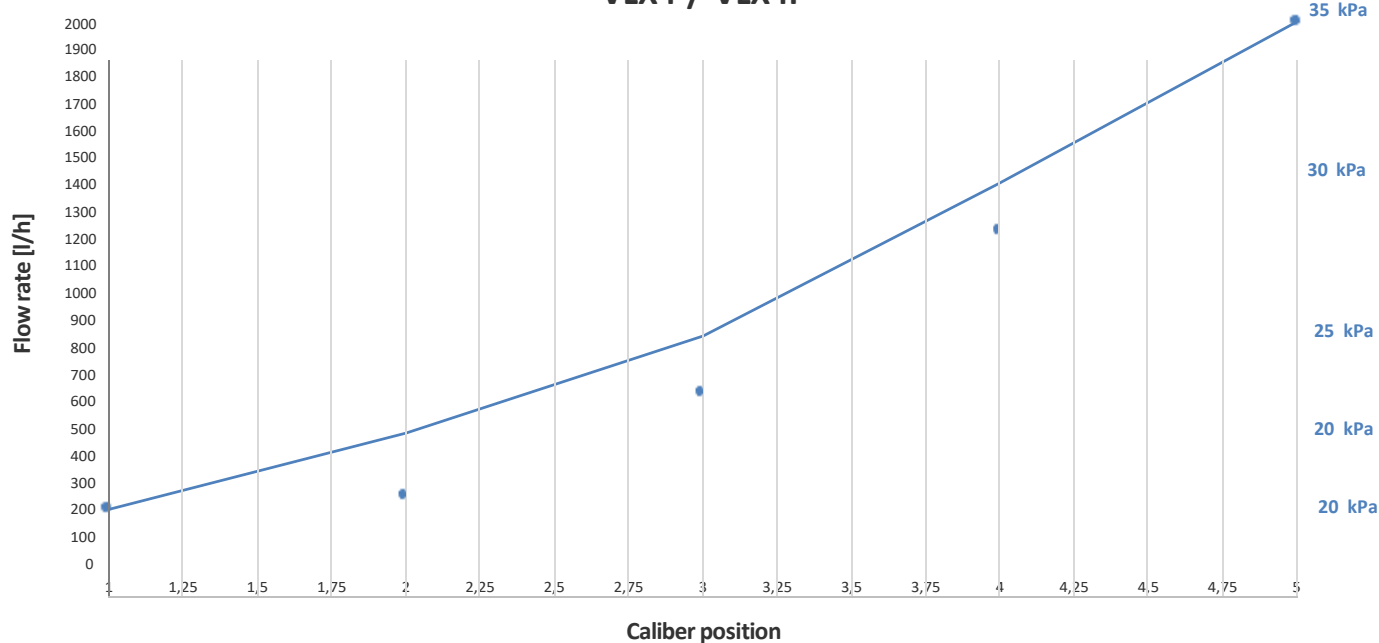

### VLX5 / VLX5P

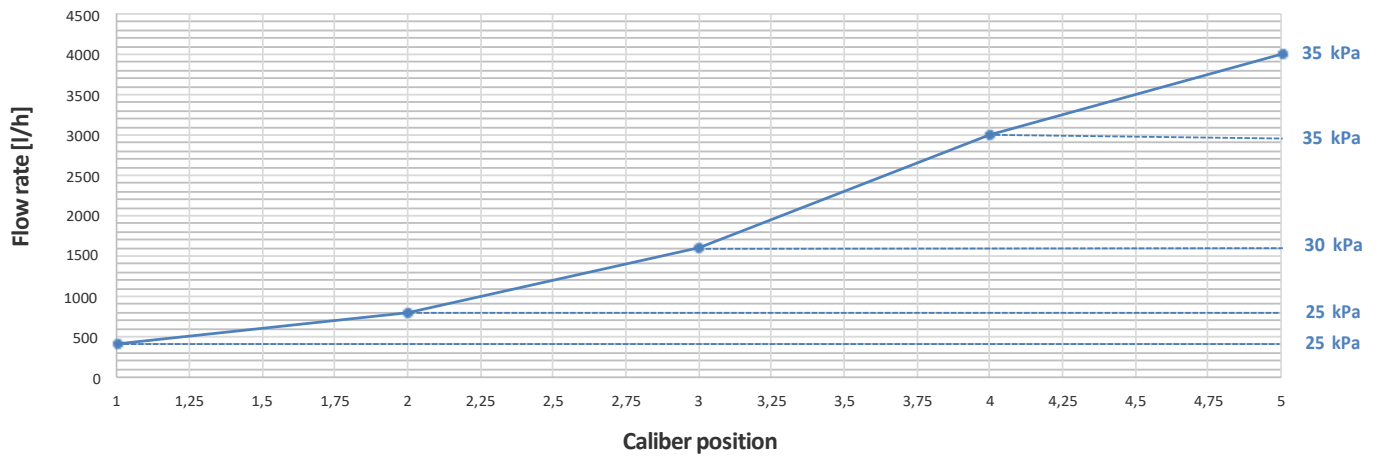

### VLX6P

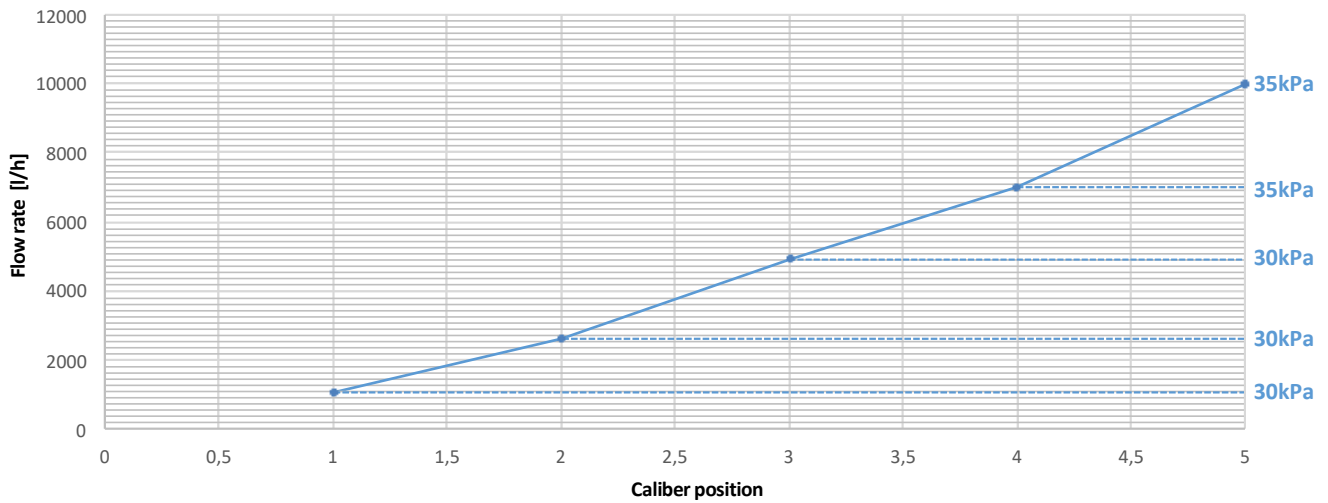

### VLX8P

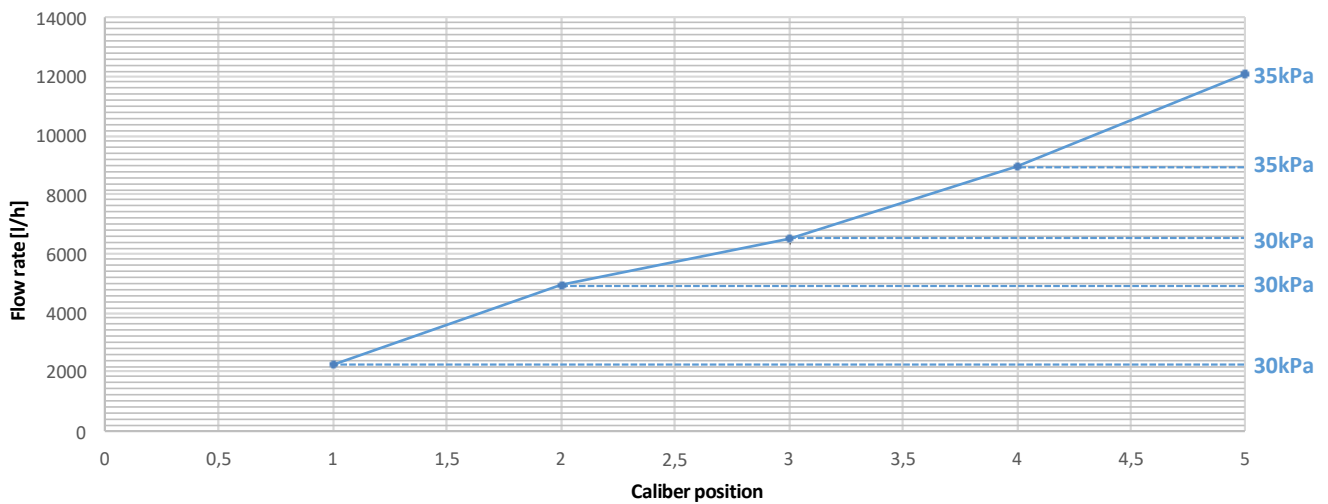

QUICKLINK SOLUTIONS S.r.l. | [info@qlsol.com](mailto:info@qlsol.com)

North West Office: Via G. Matteotti 193-203, 21044 Cavaria con Premezzo (VA), Italy

North East Office: Via F. Petrarca, 34, 35020 Albignasego (PD), Italy